

kaise

BATTERY CHECKER

Instruction Manual

SK-8551



KAISE CORPORATION

Thank you for purchasing "SK-8551 BATTERY CHECKER". To obtain the maximum performance of this instrument, read this Instruction Manual carefully, and take safe measurement.

CONTENTS

SAFETY PRECAUTIONS	1-3	PC CONNECTION	44-45
OPERATING PRECAUTIONS	4	MENU	
FEATURES	5	1. Save the Test Result	46-48
UNPACKING AND		2. View the Saved Data	49
INSPECTION	6-7	3. Delete the Saved Data	50
NAME ILLUSTRATION	8-10	4. Test Count Display	51
SPECIFICATIONS		5. Date and Time Setting	52
1. General Specifications	11	6. Language Setting	53
2. Measurement Specifications	11	7. Contrast Adjustment	53
BEFORE USE		8. Temperature Setting	54
1. Technical Words	12-13	9. Rated CCA Value Print	54
2. Language / Date & Time Settings	13	MAINTENANCE	
BATTERY TEST	14-22	1. Changing the	
SYSTEM TEST	23-26	Printer Paper	55-56
PRINT OUT	27-30	2. Printhead Cleaning	57
HEADER / FOOTER FUNCTION		3. Changing Battery Cable	58
1. Download "Header/Footer		4. Formatting the	
Editor Application"	31-33	Removable Disk	59
2. Download Template Images	34-35	5. DMP Folder	60
3. Editing Header/Footer	36-37	6. Periodical Check and	
4. Header/Footer Setting	38-39	Calibration	60
5. Variable Footer Setting	40	7. Software Version Update	60
FAVORITES FUNCTION		8. Others	60
1. Add Battery to Favorites	41-42	TROUBLE SHOOTING &	
2. Choosing from Favorites List	42	REPAIR	61-62
3. Favorites Menu	43	ABOUT KAISE WEBSITE	
		1. SK-8551 Product Page	63
		2. SK-8551 User Login Page	63
		WARRANTY	64

SAFETY PRECAUTIONS (strict observance is required)

This instruction manual contains the important contents to prevent harm to user or others and damage of property, and to use the instrument safely and correctly. Read this manual carefully and obey the contents after having understand the following terms and symbols.

■Following symbols in this manual describe the harm and damage that would be caused by incorrect ueage.



WARNING

This symbol in this manual advises the user of an electrical shock hazard that could result in serious injury or even death.



CAUTION

This symbol in this manual advises the user of an electrical shock hazard that could cause injury or material damages.

■Caution marks that require your attention (equivalent marks have the same meanings.)



This symbol shows the warnings and cautions.

















This symbol shows the prohibited matters.



This symbol shows the matters that is forced to do.

SAFETY PRECAUTIONS (strict observance is required)

WARNING

<p>Take the measurement under well-ventilated environment. The hydrogen gas which stayed around battery catches fire from the spark that occurred when connecting the Battery Clips and might explode.</p>	
<p>Make sure that the shift lever is set to "Parking" position (set to "Neutral" for stick shift vehicle). The vehicle runs accidentally and could cause unexpected accident, electric shock, fire or damage to the instrument / vehicle.</p>	
<p>Make sure that the parking brake is applied. The vehicle runs accidentally and could cause unexpected accident, electric shock, fire or damage to the instrument / vehicle.</p>	
<p>Keep the instrument away from babies or children. Important to prevent any accident, injury, or electric shock hazard.</p>	
<p>Do not use this instrument with the hands or Battery Clips wetting. Accident, electric shock, fire, or damage to the instrument / vehicle may occur.</p>	
<p>Do not take the measurement around inflammables such as gasoline or oil. Fire or explosion may occur.</p>	
<p>Do not take the measurement for the battery which does not have enough battery fluid. It causes combustion and the explosion of the battery.</p>	
<p>Do not drive the vehicle keeping the instrument connected. Accident, electric shock, fire, or damage to the instrument / vehicle may occur.</p>	
<p>Do not work in the dark place. Accident, electric shock, fire, or damage to the instrument / vehicle may occur.</p>	
<p>Do not get the instrument wet. Fire or electric shock may occur.</p>	
<p>Do not use the faulty instrument that can recognize such as display trouble, switch failure. Stop using the instrument immediately and consult with your local dealer. Using the faulty instrument may cause the unexpected accident, fire, or electric shock.</p>	
<p>Do not touch the USB port with finger or insert the foreign objects in the USB port. Accident, electric shock, fire, or damage to the instrument may occur.</p>	
<p>Do not place this instrument in any place where it will be subjected to direct sunlight, high temperatures or the inside of the sun-heated vehicles. Fire, electric shock or damage to the instrument may occur.</p>	
<p>Do not touch the heated part of the engine such as exhausting parts. Important to prevent burn injury.</p>	 

SAFETY PRECAUTIONS (strict observance is required)**⚠ WARNING**

Be careful about your hands, gloves and clothes not to be caught in the engine belt or cooling fan.

Important to prevent injury.



Do not use the instrument if it is in the abnormal condition.

Stop using the instrument immediately and consult with your local dealer when recognizing smoke, strange smell, or abnormal noise.

Using the faulty instrument may cause the accident, fire, or electric shock.



Do not attempt to disassemble or modify the instrument.

Fire, electric shock, or damage to the instrument may occur.



Do not use the cables with which coating were damaged.

Fire or electric shock may occur.

**⚠ CAUTION**

Be careful not to get the battery fluid into eyes or not to attach it to skin and clothes.

Loss of eyesight or injury may occur. If it gets into eyes, rinse immediately and submit to medical treatment.



Be careful not to jam the fingers in the Battery Clip.

It causes injury.



Be careful about the instrument or the cables not to be caught in the engine belt or cooling fan.

Short circuit or wire breaking may occur that could cause unexpected accident, electric shock, or damage to the instrument / vehicle.



Be careful about the instrument or the cables not to touch the heated part of the engine such as exhausting parts.

Important to prevent any accident, or damage to the instrument / vehicle.



Connect the Battery Clips to the battery with the correct polarity.

Reverse connection causes damage to the instrument.



When testing the battery on vehicle, take the measurement after stopping the engine and turning off the power supply of all in-vehicle apparatuses.

It causes injury or damage to the instrument.



Disconnect this instrument from battery soon after finishing the test.

It causes consumption of the battery and the ignition.



Do not hit, thrust and make scratch on the LCD display part.

It causes trouble or damage to the LCD.



Do not use the other USB cable except the supplied one.

Damage to the instrument or PC may occur.



OPERATING PRECAUTIONS

- Do not apply the engine oil to the metal part of the Battery Clips or USB Plug to prevent contact failure.
- Do not apply engine oil, gasoline, antifreeze or battery fluid to the instrument to prevent any damage on its surface.
- Do not polish the case with the fluid that contains alcohol to prevent the cracking.
- Use this instrument under the environment of -10°C to 50°C, 80%RH or less to obtain the accurate measurement. (Printer is operating at 0°C to 50°C)
- Cables which coating are heat damaged might cause the short circuit. Do not use them and replace into the new ones.
- Disconnect this instrument from battery soon after finishing the test to prevent trouble of this instrument and running out of battery power.
- Do not touch the inside of the printer with finger to prevent trouble of this instrument.
- Do not put serious pressure on Printer Lever or Printer Cover to prevent trouble or damage to this instrument.
- If Date and Time are not able to set, built-in battery for backup is exhausted. Ask KAISE AUTHORIZED SERVICE AGENCY through your local dealer for repair service.
- Keep this instrument in supplied Carrying Case to avoid malfunction of the printer trouble by dust penetration.
- Insert battery cable deeply into the unit, and fix the screw tightly. Loose connection may cause the measurement failure.
- Keep clean the battery cable, connection plugs, and terminals. Dusts may cause the contact failure.
- Do not connect battery cable oppositely. This may damage the unit and the cable.
- Do not tighten the battery cable screw too strongly. This may damage the screw or contact part of the unit, and makes them unfixable.
- Use genuine printer paper (model : 851). Using other paper could cause printing error or device failure.

Cautions for Handling

- **Do not apply mechanical shock.**
The shock such as dropping or beating might damage the instrument and may cause the trouble.
- **Do not pull cables forcibly.**
Pulling the cables forcibly, such as when removing the Battery Clips from the battery or USB Plugs from USB Port, may cause trouble such as the breaking of wire.

Cautions for Safekeeping

- **Keep away the instrument from the following place.**
 - Dusty area
 - The place where has the water splash
 - The place where applies the hard shock
 - -20°C or less, 60°C or more, 70%RH or more
 - The place where has the condensation
 - The place where is exposed to direct sunlight

FEATURES

- SK-8551 can test State of Charge (SOC), State of Health (SOH), Start Performance and Charging System of the car battery.

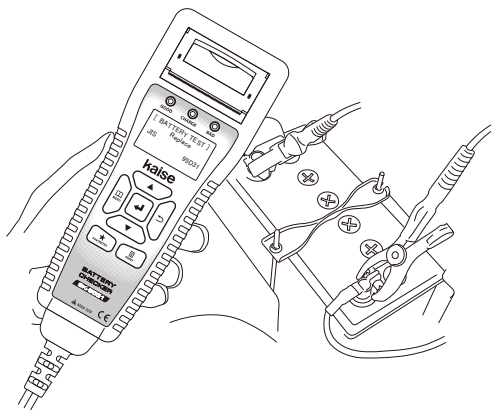

- Editable header / footer function that can print favorite names or pictures (shop name, etc.) on the printer paper.
※PC with Internet access is necessary.

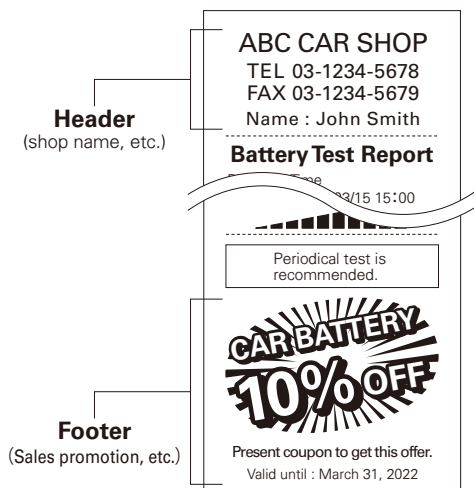

- Can record frequently tested batteries as favorites list.

- Batteries for the vehicle equipped with charge control system or idle reduction system are testable.
- Auxiliary battery for hybrid car is testable.
- Unused Battery Test Mode.
- Detachable battery cable for easy replacement.
- Test result can be printed on site by built-in printer. English or Japanese selectable.

Battery Test Report

Date and Time
2022/03/15 15:00
(Aging Test Mode)

Test Result : Good

Battery Type _____ JIS
Model No. _____ Q-85
Rated CCA _____ 590CCA
Measured CCA _____ 615CCA
Battery Voltage _____ 12.780V
Temperature _____ 24°C
Testing Mode _____
Charge controller / Idle Reduction

SOC (State of Charge) : 100%

SOH (State of Health)

System Test Report

Date and Time
2022/03/15 15:00
(12V System)

START PERFORMANCE TEST

Test Result : Good

Cranking _____ 8.619V
Start Performance _____ 100%

CHARGING SYSTEM TEST

Result : Good

- Capable of indicate additional notes on test report and saving data, which is useful for data management of vehicle or customer information.

- The software is upgradeable by connecting supplied USB cable with PC.
※PC with Internet access is necessary.

UNPACKING AND INSPECTION (Check before use)

Confirm if the following items are contained in the package in good condition.
If there are any damages or missing items, ask your local dealer for replacement.

① Battery Checker...1 pce.

② 800 Battery Cable...1 pce. (attached)

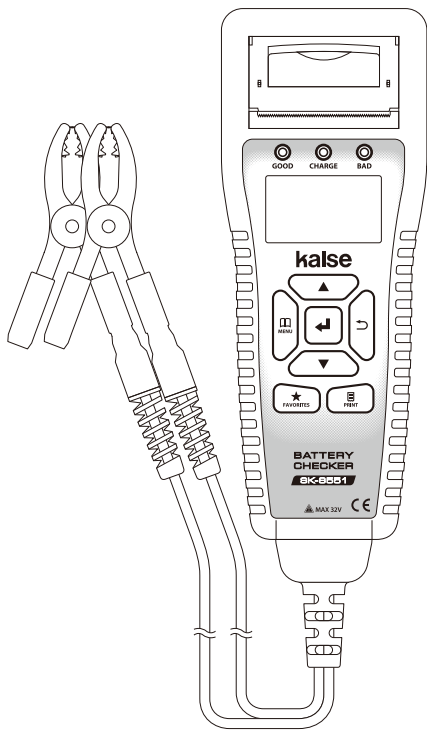

④ USB Cable (934)...1 pce.

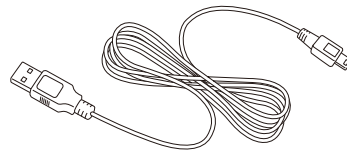

⑤ Carrying Case (1032)...1 pce.

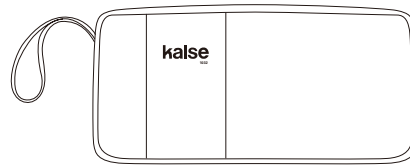

③ Printer Paper...2 rolls
(installed, and spare)

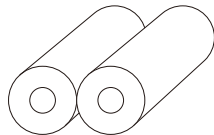

⑥ Instruction Manual...1 pce.

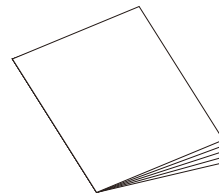

UNPACKING AND INSPECTION (Check before use)

Optional Accessories

Available Printer Paper (10pcs per set)

- Parts number: 851
 - Paper width: approx. 57mm,
 - length: approx. 5.8m
 - Paper life per 1 roll
Battery test : Approx. 50 tests
System test : Approx. 55 tests
- ※in case of standard header,
no footer, quick print.

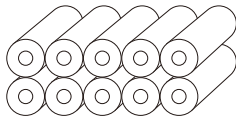

- Use above parts number when ordering.

Battery Cable

- Parts number: 800
- ※ Replaceable battery cable
by one screwdriver.

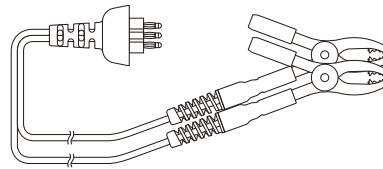

Wire Brush

- Parts number: 690
- For battery terminal cleaning (3pcs).

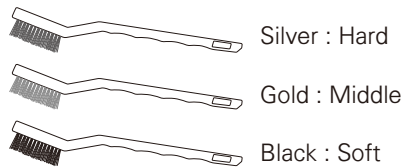

※If Date and Time are not able to set, internal backup battery is exhausted. Ask KAISE AUTHORIZED SERVICE AGENCY through your local dealer for repair service.

※The following desiccant is enclosed in the package for maintenance of quality. Throw it away after opening the package.



NAME ILLUSTRATION

Front Side

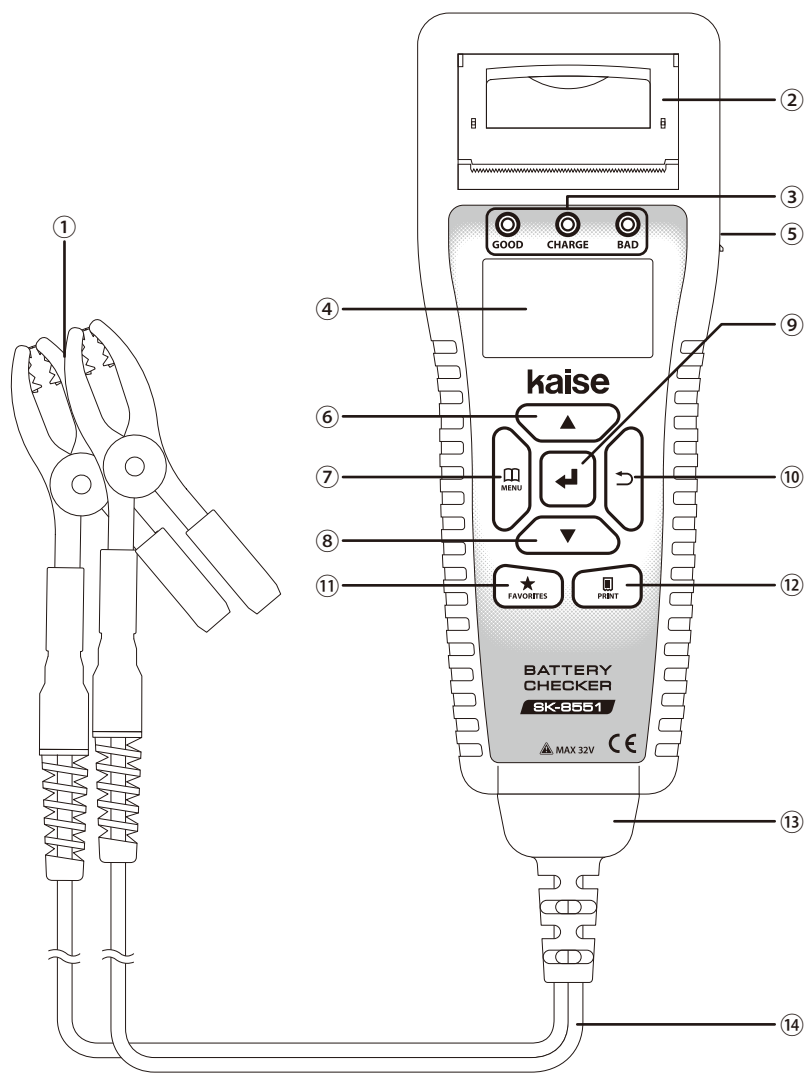

NAME ILLUSTRATION

① **Battery Clips (Red•Black) :**

- Connect to the battery. Red to ⊕, black to ⊖.

② **Printer :**

- Print out the test result, test count report, and test-print paper.

③ **LED Indicators :**

- GOOD (Green LED) :
Lights up when battery test result is "Good".
- CHARGE (Yellow LED) :
Lights up when the battery is weak and needs re-charging.
- BAD (Red LED) :
lights up when battery test result is "Replace" or needs replacement.
Flashes when battery test result is "Attention" or "Weak Start Power".

④ **LCD**

⑤ **USB Port :**

- Plug the USB Cable into this port when connecting to PC.

⑥ **△ (UP SCROLL) Key :**

- Scrolls up the display / use for numerical settings.

⑦ **☐ (MENU) Key :**

- Display the Menu screen.

⑧ **▽ (DOWN SCROLL) Key :**

- Scrolls down the display / use for numerical settings.

⑨ **↵ (ENTER) Key :**

- Press this key to fix the settings.

⑩ **↶ (BACK) Key :**

- Press this key to return to the previous screen.

⑪ **★ FAVORITES Key :**

- Press this key to add a battery to the favorites, or to open the favorites list.

⑫ **🖨️ PRINT Key :**

- Press this key to print out the test result, test count report, and test-print paper.

⑬ **Cable Connector :**

- Disconnect when changing the battery cable.

⑭ **Battery Cable :**

- Cable to connect Battery Clip and the main unit.

NAME ILLUSTRATION

Rear Side

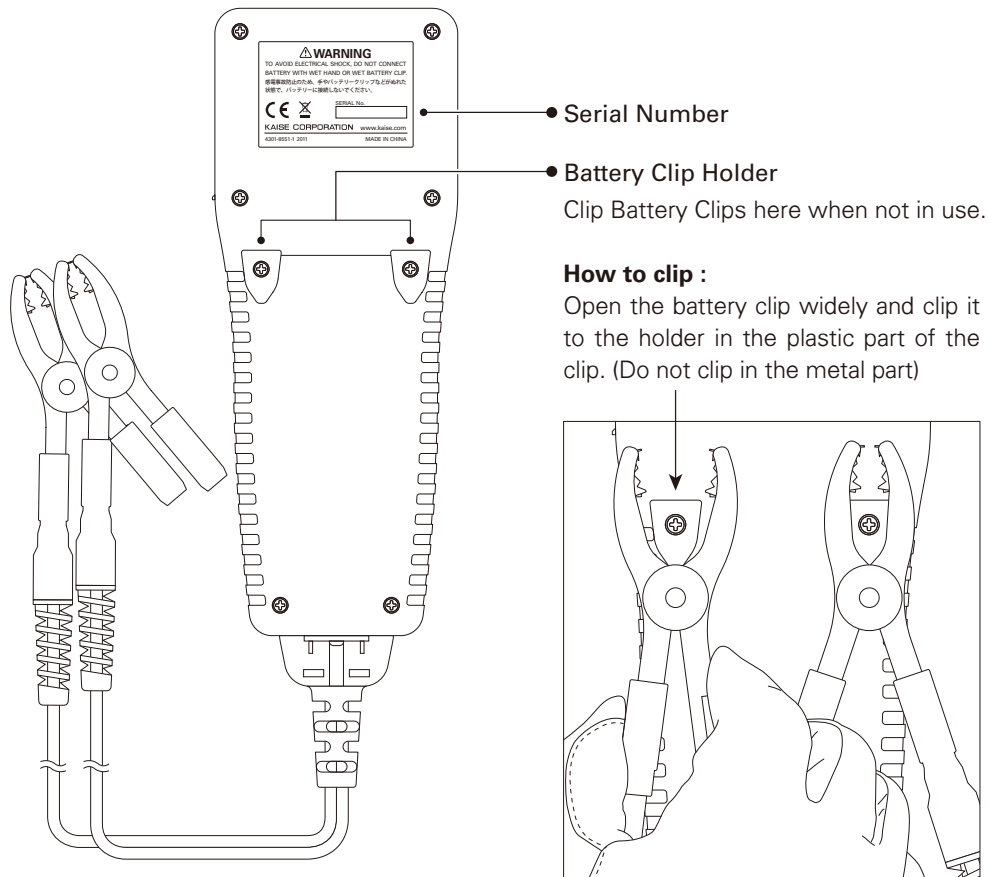

- Do not clip in the metal part of the Battery clip. To prevent any damages of the Battery Clip and Clip Holder.

SPECIFICATIONS

1. General Specifications

1. Lcd	Dot presentation, 128×64dots
2. Language	English, Japanese (Default: English)
3. Display Rate Of Voltage Measurement	1 time/second
4. Led Indication	Green: Lights up when battery test result is "Good" Yellow: Lights up when battery is weak and needs re-charging Red: Lights up when battery test result is "Replace" Flashes when battery test result is "Attention" or "Weak Start Power"
5. Printer	Built-in
6. Battery Cable Length	Approx.70cm (Clip and Bush are not included)
7. Power Supply	Testing battery or USB connection
8. Testing Voltage	DC8V to 32V (Testing battery), DC5V (USB Connection)
9. Testable Batteries	12V lead batteries ※For 24V battery, only Start-up Performance Test or Charging System Test are possible.
10. Testable Battery Standards	JIS, SBA, DIN, EN, SAE, BCI, CCA and Industrial Rating
11. Testable Battery Performance	CCA: 100 to 1400, Industrial Rating: 1.0mΩ to 50.0mΩ
12. Measurable Tests	12V battery : Battery Test / Start Performance Test and Charging System Test 24V battery : Start Performance Test and Charging System Test
13. Temperature Coefficient For Voltage Measurement	Accuracy at 23°C±5°C×0.01/°C
14. Data Saving	Test results can be saved to the internal memory up to 359 data. ※The data can be sent to PC via USB connection
15. Software Update	From web site via USB connection
16. Operating Temperature & Humidity	-10°C to 50°C, less than 80%RH (in non-condensing)
17. Storage Temperature & Humidity	-20°C to 60°C, less than 70%RH (in non-condensing)
18. Safety Level	CE marking approved EN61326-1, EN61010-1
19. Dimension	248mm(H)×96mm(W)×50mm(D) ※Cable and Bush are not included
20. Weight	Approx. 670g ※Printer paper is not included

※Specification and appearance are subject to change without notice.

2. Measurement Specifications (23°C±5°C, <80%RH in non-condensing)

Battery Voltage

Range	Accuracy	Resolution	Maximum Input
16.000V	(8V to 16V): ±0.15%±3dgt	1mV	Lower than 32V
32.000V	(16V~32V): ±0.15%±3dgt		

※Overload indication : "Over voltage" is displayed.

Temperature

Range	Accuracy	Resolution	Maximum Input
-20°C to 60°C	±3°C	1°C	-20°C to 60°C

※Accuracy is applied when measuring after leaving under constant temperature more than an hour.

BEFORE USE

1. Technical Words

• What is CCA?

CCA stands for Cold Cranking Amperes. It is defined as the current a battery at 0°F (-18°C) can discharge for 30 seconds and maintain 7.2V or more (for JIS, SAE and BCI). And it is defined as the current a battery at 0°F (-18°C) can discharge for 10 seconds and maintain 7.5V or more (for EN and DIN). The battery which has the bigger CCA, the higher ability to start an engine, CCA is one of the criterion for selection of the battery.

There are two CCA definition groups, JIS/SAE/BCI and SBA/EN/DIN, as in the below table.

CCA definition of various standards

Standards	CCA Definition	Countries
JIS	The current discharge at 0°F (-18°C) for 30 seconds and maintain 7.2V or more.	Japan
SAE		USA
BCI		USA
SBA S0102	The current discharge at 0°F (-18°C) for 10 seconds and maintain 7.5V or more.	Japan
EN		EU
DIN		Germany

※Former DIN standard is out of specification.

• What is SOH (State of Health)?

SOH is the health condition of the battery, the state is expressed in percentage (%).

Definition of SOH in this product:

SK-8551 defines SOH 30% as the threshold of the battery replacement recommendation.

Test result shows "Replacement is necessary" when measured SOH is 30% or less and test result of SOC is not "Charge/Retest".

※SOH(%) is calculated as the ratio of CCA standard value to CCA measured value.

※SOH(%) fluctuates due to the rate of deterioration and charging condition.

• What is SOC (State of Charge)?

SOC is the charging condition of the battery, the state is expressed in percentage (%).

Definition of SOC in this product:

SK-8551 defines as SOC 100% when the battery voltage is higher than 12.756V. (Higher than 13.056V for the battery for industry)

※SK-8551 does not show the exact measurement voltage when testing the battery just after an engine shutdown or just after charging. Test the battery after reducing the stimulated condition according to the procedure mentioned in page 14.

BEFORE USE

• What is Ripple Voltage?

Ripple Voltage is the feeble change of charging voltage which occurs when rectifying the generated voltage by diode. If diode is damaged, the ripple voltage fluctuated sharply and adversely affects battery and in-vehicle apparatus.

2. Language / Date & Time Settings

- Set date and time before using this instrument. (Refer to "5. Date and Time Setting" in page 53).
- Language changeable from English (default setting) to Japanese. (Refer to "6. Language Setting" in page 54).

Initial display shows the factory default settings.

BATTERY TEST

CAUTION

- This instrument forced to be restarted if the testing battery is extremely exhausted and cannot afford to supply the workable current.
- Test the battery in the state of the engine shutdown to obtain the accurate measurement.
- When testing 24V battery, test each 12V battery which is connected in series.
- When testing the battery on vehicle, test the parked car after turning off the power supply of all in-vehicle apparatuses which are using the electricity from battery and locking the car door to obtain the accurate measurement.
- Test result may change when testing the same battery repeatedly. Also, test result may change when testing the weak battery after using the printer.
- Test result may change, even when testing the same battery, depending on the battery condition or change the storage environment.
- Test results may be higher than usual just after driving. When testing the battery test of such a car, test it after doing the following procedure.
 - Turn on the headlights for approx. 20 seconds.
 - Turn off the headlights and test it more than 3 minutes after turning off the headlights.

In case of the test result is "Charge/Retest" by turning on the headlights, shorten the time of turning on the headlights after re-charging the battery, and lengthen the time of intervals before testing.

When you do not perform the procedure mentioned above or testing battery unit just after charging, test after an interval more than 2 hours.

- This instrument judges the battery condition with testing the basic use of the lead battery such as charge-discharge characteristics. Test result is not for judging whether the special control function can use for the vehicle or not.
- This instrument is for testing fundamental battery performance, charging and discharging ability, but not for judging the capability of actuating the special control function such as idle reduction system. For the batteries working with such functions, charging ability may be weakened in its using process. When the relevant functions cannot be activated, check the system details in the maintenance manual of the vehicle.
- The maximum CCA displayed with this unit is up to 1400CCA.

BATTERY TEST

Test Preparation

- Make visual inspection for the battery to be tested before connecting battery clips to the battery terminals.
- Replace the battery terminals if there is corrosion or crack occurs on the terminals.
- Connect the battery clips to the battery terminals tightly without loosening.
- Clean up the battery terminals and battery clips if there is greasy dirt.
- Do not test the battery which has any damages on its body or terminals. Replace immediately.
- As for the battery which battery fluid almost decreases to LOWER line, refill the purified water and make auxiliary charging.
- Replace the battery which battery fluid is discolored and decreases under the LOWER line.
- Check visually, if there is anything wrong with battery cable and clips.

Test the SOC (State of Charge) and SOH (State of Health) of the battery.

- ① Connect Black and Red battery clips to minus \ominus and plus \oplus battery terminals.

Make sure to touch metal serrated parts on both terminals.

- ※ Connect them to the nearest part of the terminals is acceptable if the clips cannot catch the battery terminals.

In this case, CCA may be measured lower than the actual value.

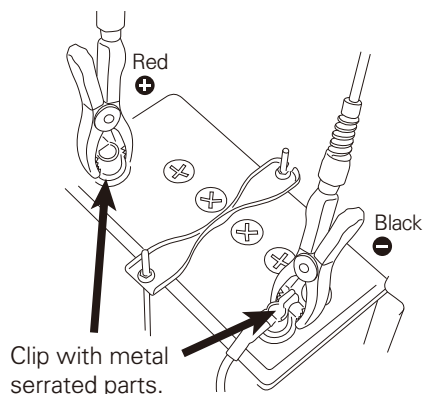

CAUTION

- Make sure to connect the battery clips tightly to battery terminals to obtain the accurate measurement.
- Connect battery clips touching metal serrated parts on battery terminals. Measurement should be incorrect if any one side is non-contacted.
- Clean up the battery terminals and the battery clips before testing to obtain the accurate measurement.

BATTERY TEST

②The instrument turns on automatically and enters "Choose the test" screen (step ③) after displaying the model number / software version number.

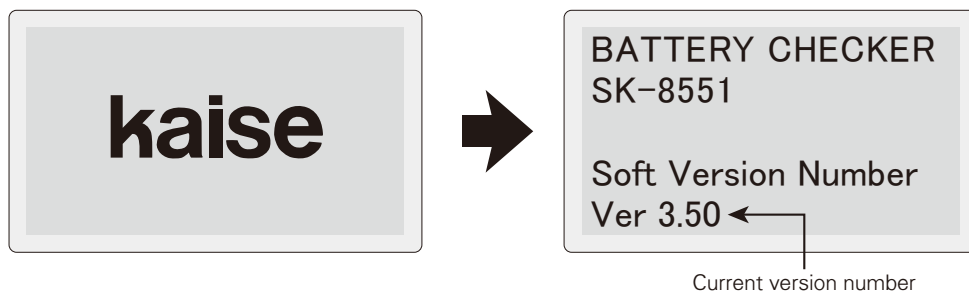

※Perform "4. Formatting the Removable Disk" in page 59 when display shows "Disk Error..." message.

※Perform "4. Formatting the Removable Disk" in page 59 when display shows this error message.

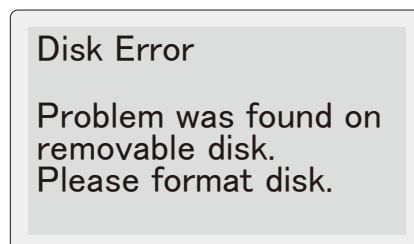

③Select Battery Test, press **↵** (ENTER) Key.
 ※Display shows the connected battery voltage.

Press **★**FAVORITES Key to open the Favorites List (see page 43).

- **☰** (MENU) Key :
Move to MENU screen. (see page 48)

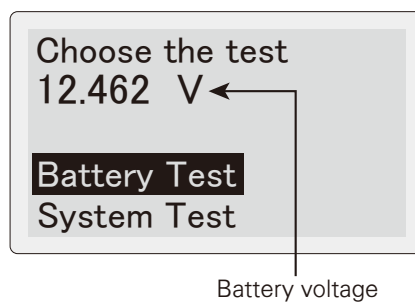

BATTERY TEST

④ Select the battery type to be tested. Select the battery type, and press **↵** (ENTER) Key.

※ Battery list : enables to choose battery models, such as JIS / SBA standards from the list.

※ Battery test does not work when the battery voltage is higher than 13.3V. LCD shows WARNING. (13.6V for industrial battery)

※ When the battery voltage is higher than 16V, LCD shows "OVER VOLTAGE" warning.

※ When testing the batteries for industrial, golf cart, leisure boat, or deep-cycle, select "Input CCA" if the CCA is shown on the battery. Otherwise, choose "Industry".

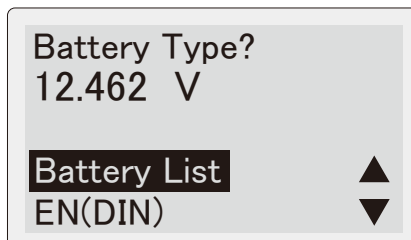

⑤ Select testing mode.

Select "Standard" for normal batteries.

Select "Charge Controller / Idle Reduction" when testing following batteries ;

- Charge control / idle reduction compatible batteries
- Batteries in Charge control / idle reduction vehicles

※ LCD shows "Industrial Rating" screen when selecting "Industry" in display ④ .

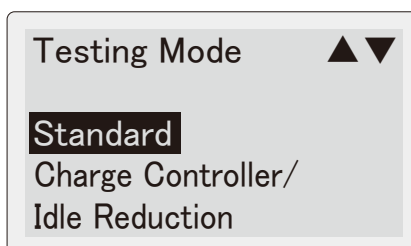

- When testing the auxiliary battery for hybrid car, select "Hybrid Auxiliary" and press **↵** (ENTER) Key.

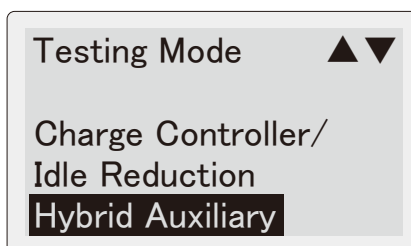

⑥ Select Test Mode.

Aging Test :
for deterioration check.

Unused Battery Test :
for condition check of unused battery

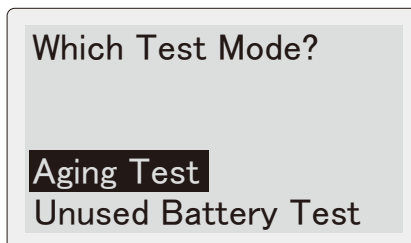

BATTERY TEST

⑦The following screen is displayed depending on the selected battery standards.

• When select Battery List

Select the test-battery group from the list, and press **↵** (ENTER) Key.

The list is classified by battery size or functions such as idle reduction, EN for Japanese cars or hybrid auxiliary.

Select the Battery ▲▼
STOP & START
 EN for Japanese cars
 Hybrid Auxiliary
 A17

Select battery number to be tested.

Press **↵** (ENTER) Key to start battery test.

Select Model ▲▼
K-42
 M-38
 M-42
 ↵ Test Start

※Selected battery standard is retained.

※If knowing only battery size like B24, D31, etc., select JIS of the greatest specifications which is replaceable.

• "EN(DIN)" / "SAE(BCI)" / "CCA input"

Input the CCA rating using **△**(UP SCROLL) / **▽** (DOWN SCROLL) Keys.

Press **↵** (ENTER) Key to start battery test.

Input EN(DIN) Rating ▲▼
 → 1400 CCA
 ↵ Test Start

※Selected battery rating is retained.

Input CCA rating

※CCA value list for each battery manufacturers and their battery models is available on KAISE website.

BATTERY TEST

• "Industry"

Select "YES" if you can input the industrial rating (internal resistance $m\Omega$) and press **↵** (ENTER) Key.

When choosing "NO", battery test starts.

※Battery condition (good / bad) is not tested when choosing "NO".



- Remove the all electric loads connected to the battery to be tested to obtain the accurate measurement.
- Battery test is effective for only 12V lead battery.
- Generally, industrial battery is recommended to be replaced when the internal resistance comes up to double of the unused battery. Based on this, SK-8551 judges "Bad" when the test result becomes double of the input industrial rating.

(When selecting "YES")

Input $m\Omega$ value with using **△**(UP SCROLL) / **▽**(DOWN SCROLL) Keys.

Press **↵** (ENTER) Key to start battery test.

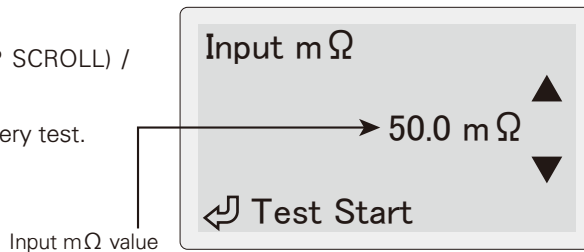

※Input internal resistance ($m\Omega$) value if it is available on the battery body or its manual.

If not, test the new (full-charged) battery selecting "NO" in the above step to record the initial internal resistance. Input that value from the next testing.

※Battery condition (good / bad) cannot be tested without inputting internal resistance ($m\Omega$) value.

※Selected resistance value is retained.

BATTERY TEST

● Input Battery Temperature

(when selecting manual temperature input in page 55, "8. Temperature Setting")

Input battery temperature in °C using
 △(UP SCROLL) / ▽(DOWN SCROLL) Keys.
 Press ◀ (ENTER) Key to start battery test.
 ※Input the temperatures of the battery fluid
 or ⊕ terminal.
 ※Selected temperature value is retained.

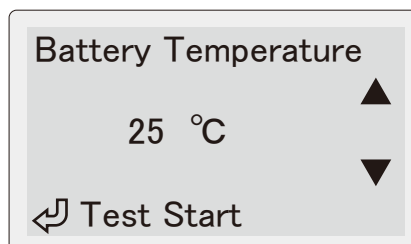

⑧ "Now testing..." is shown on LCD during battery testing.

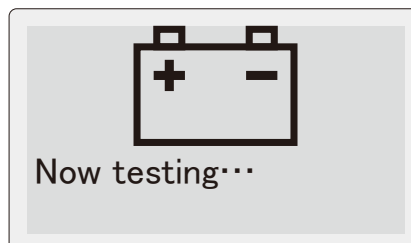

⑨ Read the test result on LCD.
 Scroll the display with △(UP SCROLL) /
 ▽(DOWN SCROLL) Keys.

You can also check the results by LED.

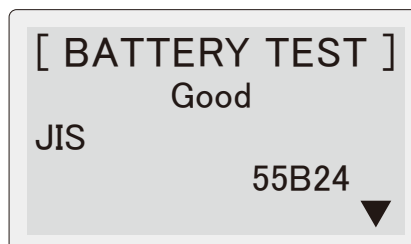
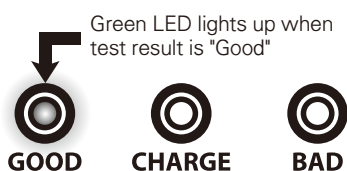

- Green lights up when test result is "Good".
- Green & Yellow lights up when the battery is fine but needs re-charging.
- Yellow lights up when re-charging and retest are needed.
- Red flashes when the test result is "Caution".
- Red lights up when battery replacement is needed.



※You can see following results on LCD.

- | | | |
|--|---|-------------------|
| ● Battery test result | ● CCA value (Standard mΩ for Industry) | ● Battery voltage |
| ● Selected battery type | ● Measured CCA (measured mΩ for Industry) | ● Testing method |
| ● Model (in battery list) | ● Temperature | ● Testing Mode |
| ● SOH (State of Health) | ● SOC (State of Charge) | ● Comment |
| ● Favorite name (when choosing the test battery from favorites list) | | |

BATTERY TEST

- Press  (MENU) Key : Move to Menu screen in page 46.
 - Press  FAVORITES Key : Add a battery or CCA rating to the favorites list. (page 41)
 - Press  PRINT Key : Move to Print screen in page 27.
- ※For the vehicle equipped with higher grade battery, start performance of engine may have no problem even if the judgment result is "Replace". In this case, battery replacement is recommended to prevent suddenly battery breakdown.
- ※The battery which is not charged for a long term may be judged "Replace" due to decreasing CCA by self-discharge even if it is a new battery. Keep the battery with periodical auxiliary charge to prevent deterioration by leaving with exhausted condition for a long term.

- ⑩ Press  (ENTER) Key.
Select "Yes" to finish the test and return to the battery type select screen (③ in page 16).

Do you want to exit?

YES
NO



CAUTION

- Do not pull Battery Clips forcibly when detaching from the battery.
It may damage the battery terminals.

- ※When intend to restart the measurement after disconnecting the battery clips, take a few seconds interval for discharging the residual electric charge from the unit.

BATTERY TEST

※Inspect following points when the instrument displays this error message.

① Check for battery clips

- Clip the battery terminals with metal serrated parts.
- Touch the metal serrated parts on the both +/- battery terminals.
- Make sure not to touch either side of the metal serrated parts on the insulated part.

② Check for the battery and vehicle

Make sure there are no dirt or abnormality on the battery terminals and terminal cables.

③ Check for SK-8551

Make sure there are not any dirt or abnormality on the metal part of battery clips and clip cables.

※Battery may be damaged if keeping getting errors in spite of checking above.

When the error message is kept displaying or measurement error is displayed even if testing another battery, ask repair service to us, KAISE CORPORATION through your local dealer.

When the unit shows this error message, immediately stop measurement and change the battery cable into the new one to avoid any accident by damaged (disconnected) cable.

※Refer to “3. Changing Battery Cable” in page 58.

Error

Restart the unit and test again.
Check error point.

Error

Battery cable disconnected.
Need replacing.

SYSTEM TEST

Test the Start Performance (check the engine starting ability) and Charging System (checking generating condition of alternator).

- ① Connect the instrument to the battery to be tested (see ① to ② in pages 15 to 16).
Select System Test, press **↵** (ENTER) Key.
※ Display shows the connected battery voltage.

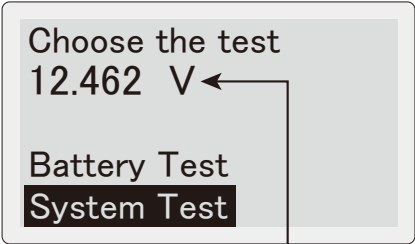

Choose the test
12.462 V

Battery Test
System Test

Battery voltage

- ② Select the battery to be tested either 12V or 24V. Press **↵** (ENTER) Key.

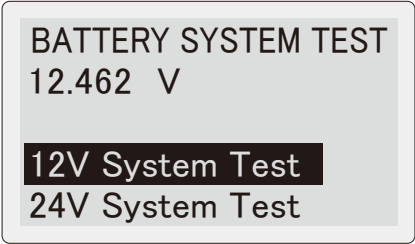

BATTERY SYSTEM TEST
12.462 V

12V System Test
24V System Test

- ③ Turn off the all electric components and press **↵** (ENTER) Key.

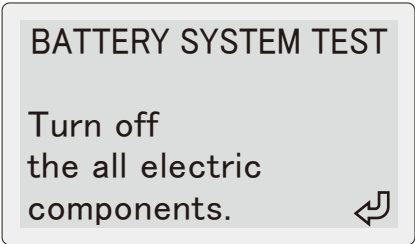

BATTERY SYSTEM TEST

Turn off
the all electric
components. **→**

SYSTEM TEST

④ Start the engine when the instrument displays the following message.

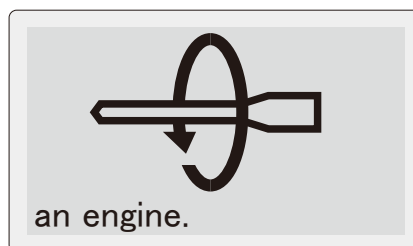
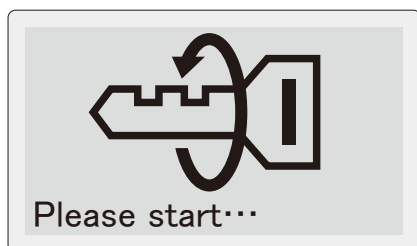

⑤ System test takes about 30 second maximum. Follow the message on the screen.

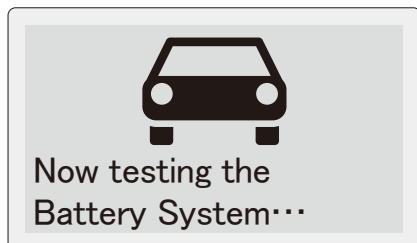

12V System

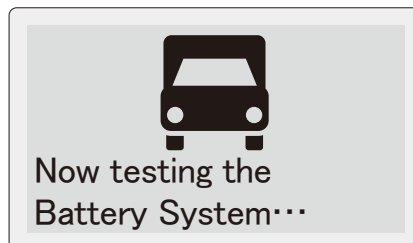

24V System

⑥ Charging System Test screen is displayed as shown in right.

Press  ENTER Key to fix the charging voltage which is varied depending on the generating condition of the alternator. Then, the instrument displays system test result as ⑦ in page 25.

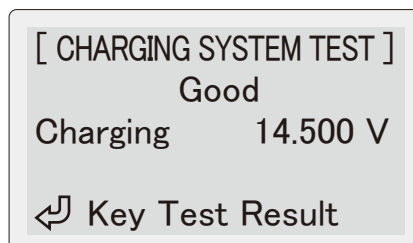

SYSTEM TEST

※The instrument displays the following message when the charging voltage is less than 13V. When measuring the vehicle with charge control system, turn on some electric components to apply electric load to the battery.

※For 24V system test, the message is shown when the charging voltage is less than 26V.

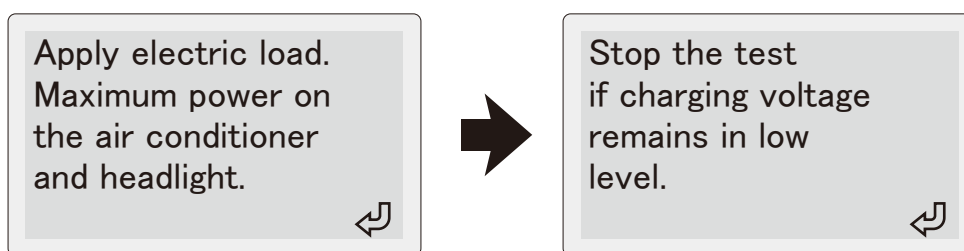

⑦ Test Result screen as shown in the right is displayed when finishing the system test.

You can scroll the screen with Δ (UP SCROLL) / ∇ (DOWN SCROLL) Keys.

You can also check the results by LED.

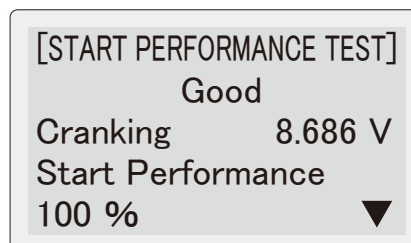
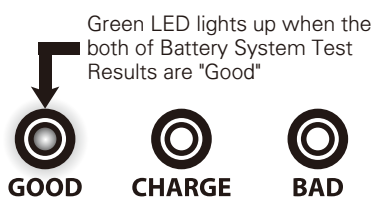

- Green LED lights up when the all test results are "Good".
- Red LED flashes when engine starter system is weak.
- Red LED lights up when the whole charging system including starter system is weak.



※You can see following results on LCD.

- Start performance test result
- Starting voltage (cranking battery voltage)
- Start performance (the ability that battery starts an engine)
- Charging system test result
- Charging voltage (battery voltage at the time of charging)
- Ripple voltage (ripple voltage of diode)
- Comment

SYSTEM TEST

- Press  (MENU) Key : Move to Menu screen in page 46.
- Press  (PRINT) Key : Move to PRINT screen in page 27.

※Though the lowest operatable / testing voltage of this instrument is 8V DC, the testing carries out normally even if the battery voltage drops lower than 8V DC during Start Performance Test.

※The unit turns off automatically when battery voltage extremely goes down under long clanking time for the reason such as weakened start performance.

※Start Performance Test is not applicable to check the starter motor condition.

※The message "Start Performance 0%" means that the tested battery almost has no power to start an engine. It does not mean the starting probability.

⑧ Press  (ENTER) Key.

Select "Yes" to finish the test and back to the test select screen (① in page 23).

Do you want to exit?

YES
NO



CAUTION

- Do not pull Battery Clips forcibly when detaching from the battery. It may damage the battery terminals.

※When intend to restart the measurement after disconnecting the battery clips, take a few seconds interval for discharging the residual electric charge from the unit.

PRINT OUT

Print out the Battery Test and System Test results from built-in printer.

※Unclear printing or unstable operation of this instrument may occur when using weak battery for printing. In this case, save the test results in reference to "1. Save the Test Result" in page 46, then print them out with good battery or PC in reference to " PC Connection" in page 44.

① Press  (PRINT) Key in Battery Test result (⑨ in page 20) or System Test result (⑦ in page 25) screens to enter Print screen.

- Quick Print : The results printed out directly without additional input.
- Add Information, Print : Open the screen ② enabling to input additional notes.

※If printing becomes dark by continuous printing, stop printing for a while for cooling down the printer thermal head.

② Use below keys to input and print additional notes.

 (UP/DOWN SCROLL) Key — Choose

 (ENTER) Key — Decide

 MENU Key — Space

★ FAVORITES Key — Change Input

(Uppercase letter → Lowercase letter →



Numeral → Symbol → Digit →

return to Uppercase letter)

 (BACK) Key — Delete

★ FAVORITES Key (long press) — Delete all

 (ENTER) Key (long press) — Return

③ Press  (PRINT) Key to show the confirmation screen. Choose "Yes" and press  (ENTER) Key to print out the test result.

※Texts are retained enabling to show the next input.

Do you want to print ?

Quick Print

Add Information, Print
No

TOYOTA-Prius

ZVW50

No. XX-XX

★ : Input (Upper Case)

▲▼ : Select  : Enter

TOYOTA-Prius

ZVW50

No. XX-XX

is OK ?

YES

NO

PRINT OUT

※When the thermal head is too much heated, warning shown on LCD and printing stops. Leave the unit for a while for cooling down.

High temperature,
printing quality declined.

Cool down the printer,
for some time.

※The instrument displays right screen during printing. After finishing, go back to test result screen.

※Make sure to close printer cover to avoid any printing error.

※When paper jam occurs, open the printer cover and fix the paper.



Now printing...

※The instrument displays right screen when printer paper is almost empty or unset. Set new printer paper as per "1. Changing the Printer Paper in page 55.

※This screen may not be displayed depending on the sensor sensitivity.

※Use genuine printer paper (model : 851). Using other paper could cause printing error or device failure.



Paper out...

PRINT OUT

Printing Sample

※Saved data is printed out with a current setting language of this instrument.
 (e.g. : The data saved in Japanese is printed in English if the present setting is "English".)

■ Battery Test

XXXXXXXXXXXXXXXXXX
 XXXXXXXXXXXXXXX
 XXXXXXXXXXXXXXXXXXXX

Battery Test Report

Store Name _____

Person in Charge _____

Date and Time
 2022/03/15 15:00 •

(Aging Test Mode) •

Test Result : Good •

Battery Type _____ EN (DIN)
 Rated CCA _____ 700CCA
 (20-72 (AC Delco)) •

Measured CCA _____ 715CCA
 Battery Voltage _____ 12.780V
 Temperature _____ 24°C
 Testing Mode _____
 Charge controller / Idle Reduction

SOC (State of Charge) : 100% •

SOH (State of Health) : 100% •

Periodical test is recommended.

Additional Information
 (if this printing mode is selected)

Store name and person in charge
 ※when header setting is "Standard"
 (refer to ③ in page 38)

Testing date and time

Battery test mode

Battery test result

"Favorites" name
 ※Battery model No. for the favorites
 from battery list.

Condition of tested battery

Battery charging level (SOC)

Battery aging level (SOH)

Comment for test result

You can add "Header" and "Footer" on the printing paper. For details, refer to "Header / Footer Function" in page 31.

PRINT OUT

■ System Test

XXXXXXXXXXXXXXXX XXXXXXXXXXXXXXXX XXXXXXXXXXXXXXXX	Additional Information (if this printing mode is selected)
<h3 style="margin: 0;">System Test Report</h3>	
Store Name	Store name and person in charge ※when header setting is "Standard" (refer to ③ in page 38)
Person in Charge	
Date and Time	Testing date and time
2018/03/15 15:00 •	
(12V System) •	12V / 24V System
START PERFORMANCE TEST	
Test Result : Good •	
Cranking ————— 8.619V	Engine start performance test result Battery conditions at engine starting
Start Performance ——— 100%	
CHARGING SYSTEM TEST	
Test Result : Good •	
Charging Voltage ——— 14.523V	Charging system test result Battery conditions
Ripple Voltage ————— 0.110V	
Periodical test is recommended.	Comment for test result

You can add "Header" and "Footer" on the printing paper. For details, refer to "Header / Footer Function" in page 31.

HEADER / FOOTER FUNCTION

You can add "Header" and "Footer" on the printing paper.

※PC and Internet access are required.

(Example)

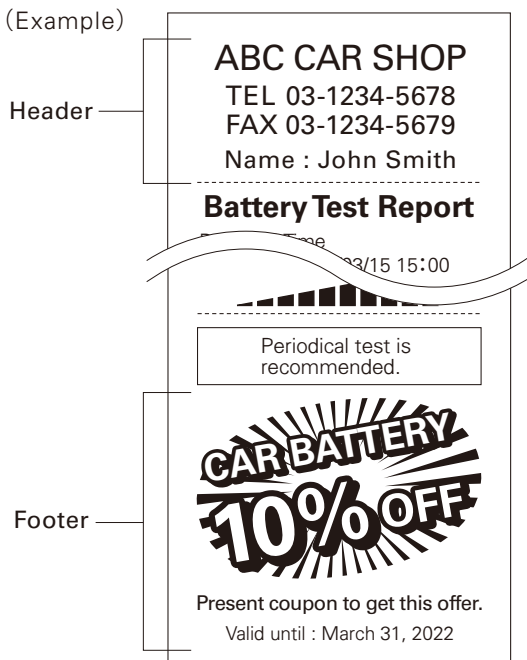

See the below procedures to make "Header" and "Footer" like the left example.

- **Header** : Characters
- **Footer** : Template coupon & Characters

1. Download "Header/Footer Editor Application"

Kaise Corporation is not liable for any direct or indirect damage, problem, prejudice or conflict caused by use of "Header/Footer Editor Application".

① Access to the following URL via PC.

SK-8551User Login URL

https://www.kaise.com/sk8551ex/e_car_sk8551ex.html



You can also access through :

Kaise Website (<https://www.kaise.com/NewEnglish.htm>) → Products →

Automotive Testers → SK-8551 Battery Checker → "User Login" banner

HEADER / FOOTER FUNCTION

②Login with the following user name and password.

※The above User Name and Password are in common with the all SK-8551 users.

Sign in
https://www.kaise.com

Username SK-8551

Password

Sign in Cancel

Input User Name

Input Password

※Be sure to write uppercase and lowercase letters correctly as written above.

※The above login window may differ depending on the internet browser.

③Enter "SK-8551 Battery Checker User Page". Click the below "Download" banner to download the software "Header/Footer Editor Application" enable to install the Header and Footer into the SK-8551.

kaise

HOME Products Corporate Profile Support Download User registration Contact Us

HOME Automotive Testers SK-8551 User Login Page

SK-8551 Battery Checker User Login Page

Header/Footer Editor Application

Click this banner to download the application software to make header and footer on the printing page.

(Supported OS: Windows XP / Vista / 7 / 8 / 10 / 11)

BATTERY CHECKER Header/Footer Editor

Download

More info

Run anyway

Click "Download" banner.

Template Images

HEADER / FOOTER FUNCTION

- ④Click "Save" when the below download windows is shown.
※The window may differ depending on the internet browser.

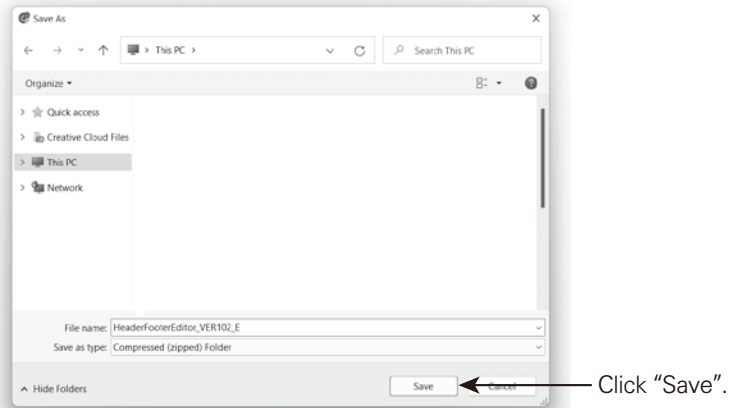

- ⑤Unzip downloaded ZIP file (HeaderFooterEditor_VERXXX_E), then copy the inside folder (HeaderFooterEditor_VERXXX_E) to desktop.

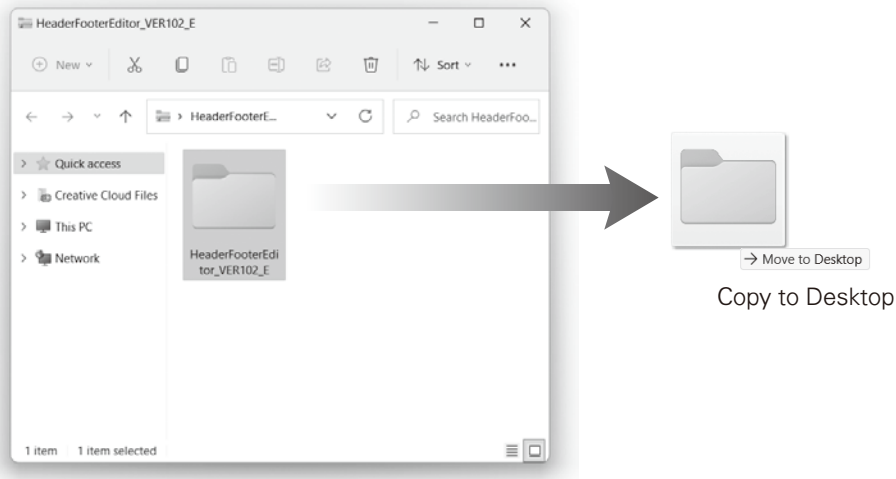

- ⑥Downloading of "Header/Footer Editor Application" is finished. Be sure to keep saving the copied desktop folder (HeaderFooterEditor_VERXXX_E).

HEADER / FOOTER FUNCTION

2. Download Template Images

①Enter “User Login Page”, and click the below template Image “CAR BATTERY 10% OFF”.

※You can download the all images in the same group.

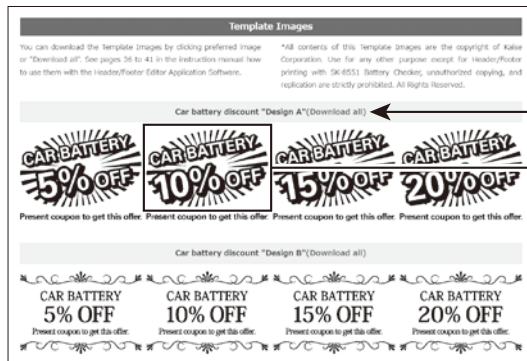
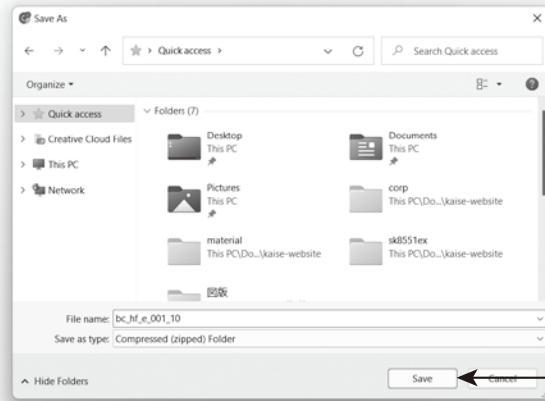

Image group download.

Click this image
“CAR BATTERY 10% OFF”.

②Click “Save” when the below download windows is shown.

※The window may differ depending on the internet browser.



Click “Save”.

HEADER / FOOTER FUNCTION

- ③Unzip the downloaded ZIP file (bc_hf_001_1000). Copy the inside BMP file to “Image folder” in “HeaderFooterEditor_VERXXX” folder which is downloaded in page 33.

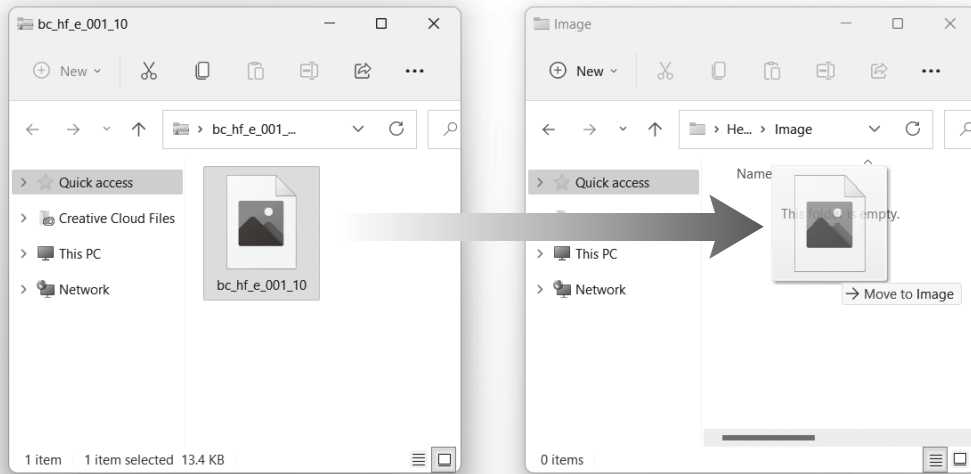

Template image ZIP file

Unzip and copy to “Image folder” in
“HeaderFooterEditor_VERXXX” folder

Be sure to save the downloaded template images or original image data in the above “Image folder”.

HEADER / FOOTER FUNCTION

3. Editing Header/Footer

① Connect SK-8551 and PC with USB cable (see page 44).

※ This connection is needed to activate “Header/Footer Editor Application”.

② Open “HeaderFooterEditor_VERXXX” downloaded in page 33.

Then, open HeaderFooterEditor file inside.

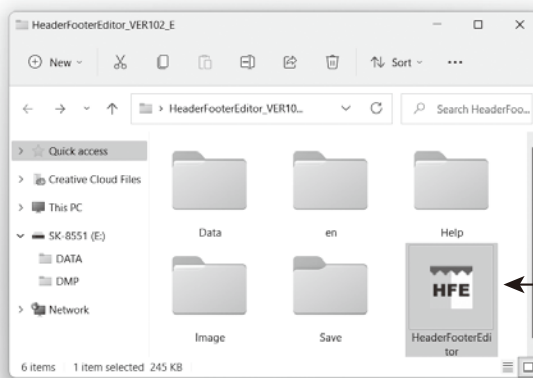

Open HeaderFooterEditor file

Header/Footer Editor Application folder

③ Software License Agreement window is displayed. Click “Agree” if you can agree to the terms of service.

※ In case of “Disagree”, you cannot use this software application.

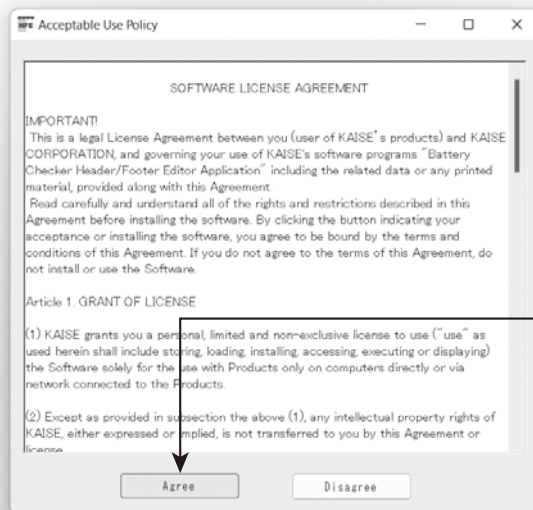

Click “Agree”.

HEADER / FOOTER FUNCTION

④“Header/Footer Editor Application” is activated.

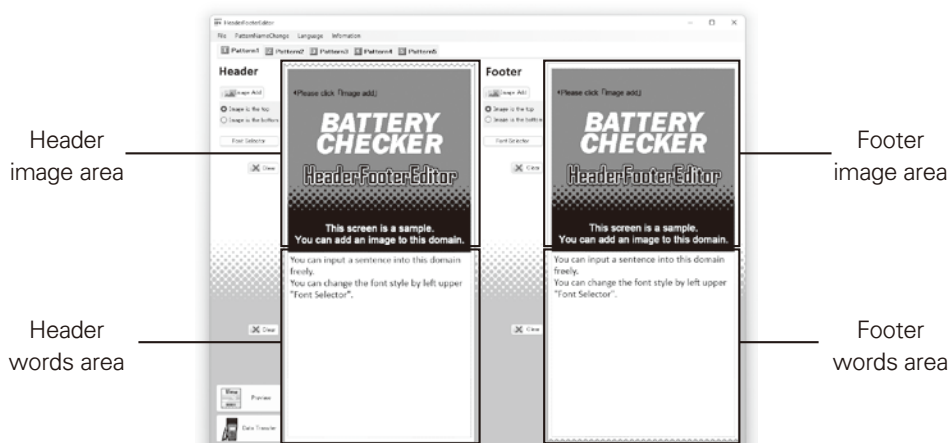

⑤Follow the below steps to make the same Header and Footer as shown in the page 31.

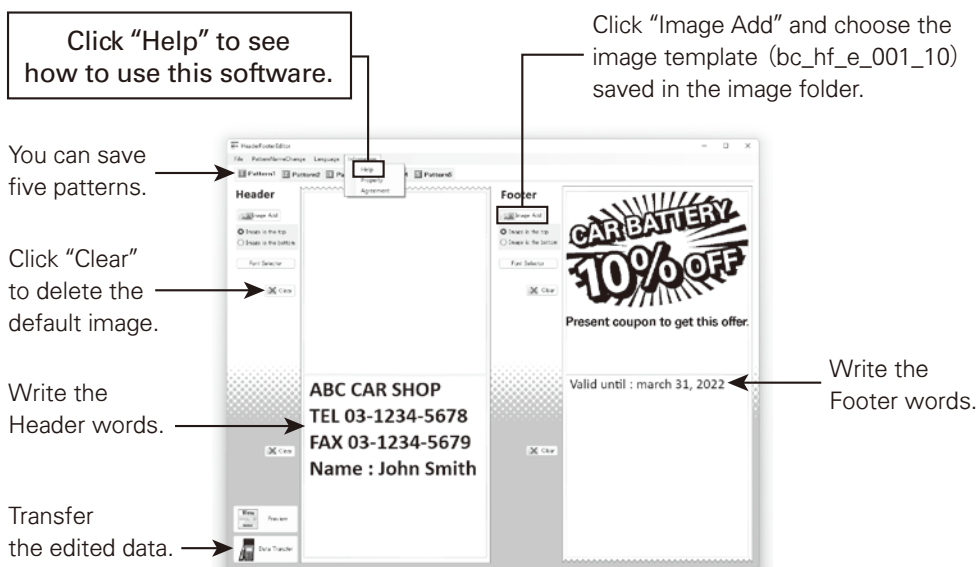

⑥Save the edited Header/Footer data.

⑦Click “Data Transfer” to send the data to SK-8551. Follow the instructions on screen.

⑧After data transfer, re-connect SK-8551 and PC. Follow the instructions on screen.

⑨When “USB Connect ...” is displayed, disconnect PC from SK-8551.

※Release any data copy restrictions if it is imposed in your USB port.

HEADER / FOOTER FUNCTION

4. Header/Footer Setting

Set Header/Footer for the SK-8551 printing.

- ① Connect SK-8551 to the battery to turn on.
- ② Press  MENU Key when "Choose the test" screen is displayed. MENU screen on the right is displayed. Choose Header/Footer Setting.

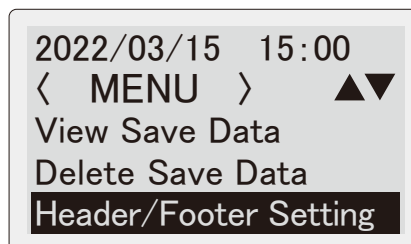

- ③ Header/Footer Setting screen is displayed as below, with print settings for each of Battery Test and System Test.
The following steps show the sample how to set Header/Footer for Battery Test printing. Choose Battery Test, and enter.

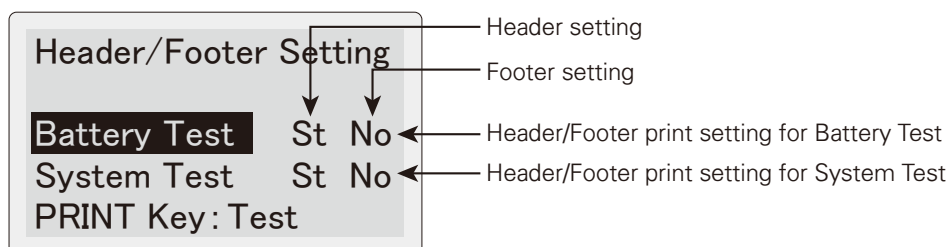

St : Standard (Print default setting image)

No : No print (No Header/Footer printed)

1 : Pattern 1 (Header/Footer saved as Pattern 1 is printed)

2 : Pattern 2 (Header/Footer saved as Pattern 2 is printed)

3 : Pattern 3 (Header/Footer saved as Pattern 3 is printed)

4 : Pattern 4 (Header/Footer saved as Pattern 4 is printed)

5 : Pattern 5 (Header/Footer saved as Pattern 5 is printed)

Te : Test result (Can print variable Footer depending on the test result.)

※ See page 41. Only effective for Battery Test result.

Refer to "Help" in "Header/Footer Editor Application" how to save the patterns.

Tips for Header/Footer!

You can print the mechanic name easily by setting each of their names for Pattern 1 to 5.

HEADER / FOOTER FUNCTION

④Header Select screen is displayed.

Choose the Pattern name saved in page 37.

◆ mark = current setting →

Battery Test
Header Select ▲▼
Not Use
◆ Standard
1:Pattern1

⑤Footer Select screen is displayed Choose the Pattern name saved in page 37.

Battery Test
Footer Select ▲▼
◆ Not Use
1:Pattern1
Test Result

⑥Return to the "Header/Footer Setting" screen. Confirm the selected pattern names are displayed.

Set the System Test Header/Footer printing in the same way, if needed.

Header/Footer Setting

Battery Test	1	1
System Test	St	No

PRINT Key: Test

← Selected pattern names are displayed.

⑦Header/Footer Settings are finished. Run the trial Battery Test to check if the Header and Footer can be printed correctly.

※You can print test print paper by pressing PRINT Key.

HEADER / FOOTER FUNCTION

5. Variable Footer Setting

You can print variable Footer depending on the test result. (up to 5 patterns)

※This function is not available for Header.

※Only effective for Battery Test. Not available for System Test.

- ①Choose "Test Result" on Battery Test-Footer Select screen in ⑤ of page 39.

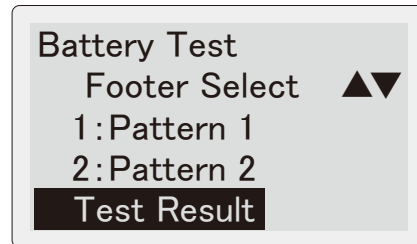

- ②Variable Footer Setting screen is displayed. Choose the print pattern name for each test result (blinking → choose → stop blinking). Choose Finish in the last page to finish the setting.

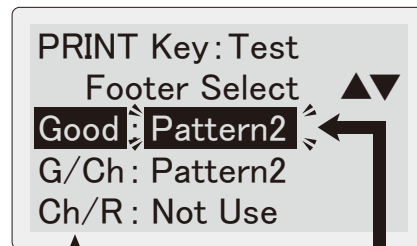

■ Test Result names

Good : Good	Atte : Attention
G/Ch : Good/Charge	Bad : Replace
Ch/R : Charge/Retest	

This side
blinking

Tips for Variable Footer!

When printing the coupon on the footer, changing the contents as per the test result is recommended. Refer to following examples.



Good or Good/Change



Attention or Replace

FAVORITES FUNCTION

You can bookmark the frequently-test battery as "Favorites". This function is useful for easy battery setting when testing.

1. Add Battery to Favorites

- ① Press **★** FAVORITES Key on Battery Test Result screen in page 20.
 Choose "YES", then go to the screen ②.
 ※ This screen is not displayed when choosing the testing battery from Favorites List in page 42.

Do you want to add?

YES
NO

- ② You can change the battery name as you like. Use below keys for editing.

△▽(UP/DOWN SCROLL) Key — Choose
 ↵(ENTER) Key — Decide
 □ MENU Key — Space
 ★ FAVORITES Key — Change Input
 (Uppercase letter → Lowercase letter →
 Numeral → Symbol → Digit →
 return to Uppercase letter)
 ⏪(BACK) Key — Delete
 □ PRINT Key — Finish

Q-85

▲▼ : Select ↵ : Enter
 MENU : space
 ★ : Input(Upper Case)
 ⏪ : Delete PRINT : Exit

- ③ Press □ PRINT Key to display the confirmation screen.
 Choose "YES" to complete.
 ※ Up to 50 batteries can be stored in the Favorites list.

Q-85
is OK?

YES
NO

FAVORITES FUNCTION

Tips for the Favorites!

For EN(DIN), SAE(BCI), or industrial batteries, adding the frequently-test CCA or mΩ rating to the favorites list is useful to skip their input.

※In the below examples, their names are changed for easy choosing.

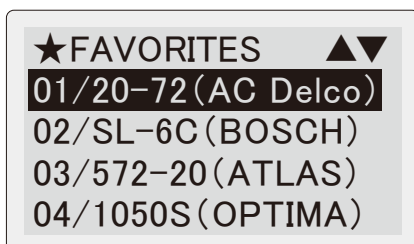

Example for EN(DIN) or SAE(BCI)

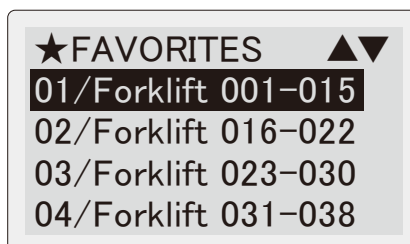

Example for industrial battery

2. Choosing from Favorites List

① Press ★ FAVORITES Key on “Choose the test” screen in ③ or page 16. Favorites List screen is displayed.

※ “No data found.” is displayed when no battery is listed.

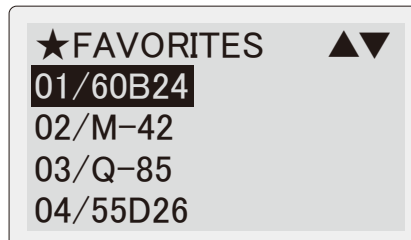

② Choose the battery name to be tested. After choosing, screen moves to “Testing Mode” screen.

※ For the battery marked as favorite from the “battery list”, selected test mode is stored together. In this case, display moves to “Which Test Mode?” screen retaining that test mode.

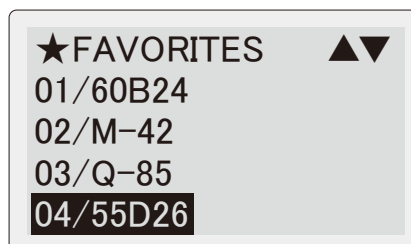

FAVORITES FUNCTION

3. Favorites Menu

① Press **MENU** Key to open Favorites Menu screen.

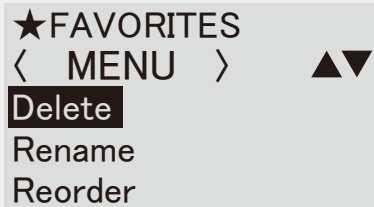

★ FAVORITES
 < MENU > ▲▼
 Delete
 Rename
 Reorder

② Delete : You can delete the selected battery in the Favorites List.

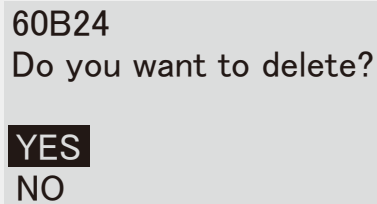

60B24
 Do you want to delete?
 YES
 NO

③ Rename : You can change the selected battery name in the Favorites List. Refer to ② of page 41 how to change the name.



60B24
 ▲▼ : Select ↵ : Enter
 MENU : space
 ★ : Input(Upper Case)
 ⇨ : Delete PRINT : Exit

④ Reorder : You can sort Favorites List. Choose the batteries in order you want to display and decide. After deciding the all listed batteries, start sorting and return to the Favorites List screen.



FAVORITES reorder ▲▼
 60B24
 02/M-42
 01/Q-85
 55D26

PC CONNECTION

SK-8551 can connect to PC via provided USB cable. You can send saved test data to PC in text format.

- ① Insert the provided USB cable to the USB port on the right side of the unit and connect another side to PC.

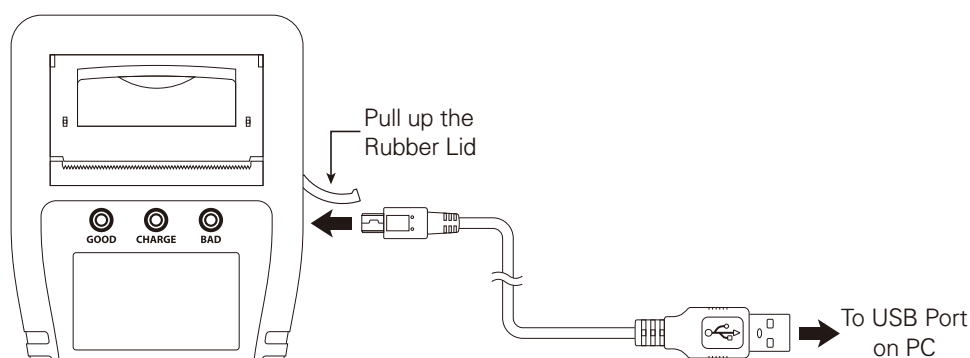

- ② The instrument turns on automatically when connecting to active PC. Messages as shown in the right are displayed.

※ Internal memory is recognized as mass-storage device (kaise SK-8551 USB Device) when PC connection is completed.

※ If your PC does not recognize the SK-8551, try to use another USB port or to connect through commercially available USB hub.

※ It may take time to recognize the devise.

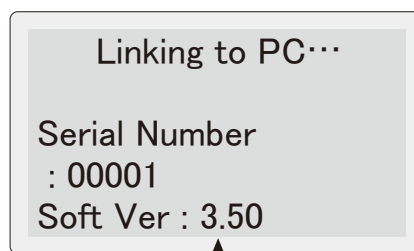

Current version number is displayed.

CAUTION

- Detach USB Cable after completing USB removing process from PC to prevent unexpected trouble.

※ When intend to restart the measurement after disconnecting the battery clips, take a few seconds interval for discharging the residual electric charge from the unit.

PC CONNECTION

- ③ Access to the memory of this instrument by PC operation to copy and paste the data to the PC. Data format is "text" which is suitable for print out from PC.

〈Examples of saved data〉

■ Battery Test

```

2231501B.TXT - Notepad
File Edit Format View Help
-----
XXXXXXXXXXXXXXXXXX
XXXXXXXXXXXX
XXXXXXXXXXXXXXXXXX
-----
Battery Test Report

Date and Time 2022/03/15 15:00
-----
(Aging Test Mode)
-----
Test Result: Good

Battery Type: JIS
Battery Size: Q-85
Rated CCA: 590CCA
Measured CCA: 615CCA
Battery Voltage: 12.780V
Battery Temperature: 24°C
Testing Mode
: Charge Controller/Idle Reduction

SOC (State of Charge): 100%
■■■■■■■■■■■■■■■■■■■■
SOH (State of Health): 100%
■■■■■■■■■■■■■■■■■■■■
-----
Comment
-----
Periodical test is recommended.
-----
    
```

Additional Information (if available)

Test date and time

Test mode

Test result

Details of tested battery

Battery charging level (SOC)

Battery aging level (SOH)

Comments for test result

■ System Test

```

2231501S.TXT - Notepad
File Edit Format View Help
-----
XXXXXXXXXXXXXXXXXX
XXXXXXXXXXXX
XXXXXXXXXXXXXXXXXX
-----
System Test Report

Date and Time 2022/03/15 15:00
-----
(12V System)
Start Performance Test

TestResult: Good

Cranking: 8.619V
Start Performance: 100%
-----
Charging System Test

Test Result: Good

Charging Voltage: 14.523V
Ripple Voltage: 0.110V
-----
Comment
-----
Periodical test is recommended.
-----
    
```

Additional Information (if available)

Test date and time

12V/24V system

Test result

Result details

Test result

Result details

Comments for test result

※ Test data are displayed in the language used for data saving.

- ④ Detach USB Cable after completing "Safety Remove Hardware" process from PC.

※ When intend to restart the measurement after disconnecting the battery clips, take a few seconds interval for discharging the residual electric charge from the unit.

※ Windows is a registered trademark of the Microsoft.

MENU

1. Save the Test Result

Save the results of **Battery Test** and **System Test** up to **359 data**.

※Each data is saved with following file name.

■ Example of file name (In case of the third time on the same day, May 15th, 2022)

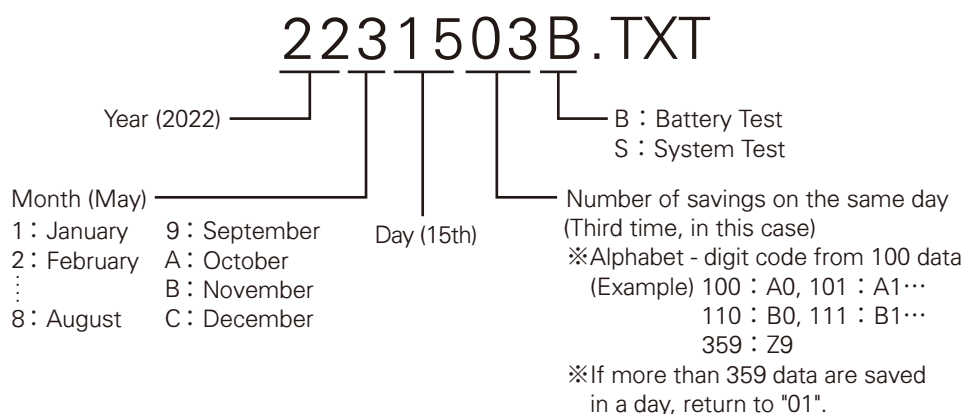

※Saved date and time reflect the date and time settings of this instrument. Make sure to set them correctly in reference to "5. Date and Time Setting" in page 52.

- ① Press **MENU** (MENU) Key in Battery Test result (⑨ in page 20) or System Test result (⑦ in page 25) screens enter Menu screen.
Select "Save Data" and press **ENTER** (ENTER) Key.



- ② Select "Quick Save" to save the data without additional notes.
Select "Add Information, Save" to input additional notes. See ③ for details.

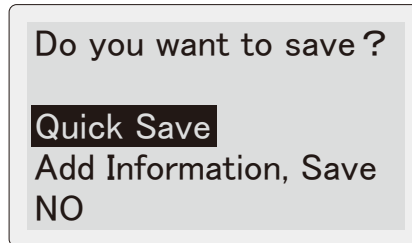

MENU

- ② Use below keys to input and save additional notes.

- △▽(UP/DOWN SCROLL) Key ———— Choose
- ↵(ENTER) Key ———— Decide
- ☐ MENU Key ———— Space
- ★ FAVORITES Key ———— Change Input
(Uppercase letter → Lowercase letter →
Numeral → Symbol → Digit →
return to Uppercase letter)
- ↶(BACK) Key ———— Delete
- ★ FAVORITES Key (long press) ———— Delete all
- ↵(ENTER) Key (long press) ———— Return

- ④ Press ☐ (PRINT) Key to show the confirmation screen. Choose "Yes" and press ↵(ENTER) Key to complete data saving.

On PC, you can see the above notes on the top of the saved data. Refer to page 45 for details.

- ※ Texts are retained enabling to show the next input.

TOYOTA-Prius
ZVW50
No. XX-XX
★ : Input (Upper Case)
▲▼ : Select ↵ : Enter

TOYOTA-Prius
ZVW50
No. XX-XX
is OK ?

YES
NO

MENU

※Up to 359 data can be saved to the internal memory. The instrument displays this WARNING if the saved data exceeds 359. Delete unnecessary data in reference to "3. Delete the Saved Data" in page 50.

-WARNING-
Can't save the data.
The number of saved data exceed the limit.

※The instrument displays this WARNING when the memory capacity shortage. Delete unnecessary data in reference to "3. Delete the Saved Data" in page 50 to make the storage capacity.

-WARNING-
Can't save the data.
Out of memory capacity.

※The instrument displays this WARNING when the same data already exists. Delete the relevant in reference to "3. Delete the Saved Data" in page 50.

※File name consists of the saving date. Refer to "Example of file name" in page 46 for details.

※Saved data are deletable from PC (refer to "PC Connection" in page 44).

-WARNING-
Can't save the data.
The same file name existed.

※The instrument displays this message when the system error occurs.

Stop test and format the removable disk in reference to "4. Formatting the Removable Disk" in page 59.



※All of the saved data are deleted after formatting removable disk.

System Error
Can't save the data.

MENU

2. View the Saved Data

Recall the saved data to see on the screen.

- ① Press  (MENU) Key in "Choose the Test" screen (③ in page 16) to enter Menu screen. Select "View Save Data" and press  (ENTER) Key.

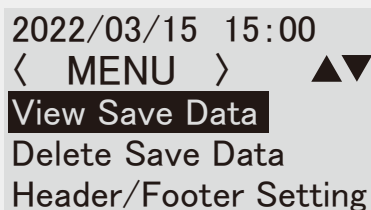



2022/03/15 15:00
 < MENU > ▲▼
View Save Data
 Delete Save Data
 Header/Footer Setting

- ② Select the data that you want to see, and press  (ENTER) Key.

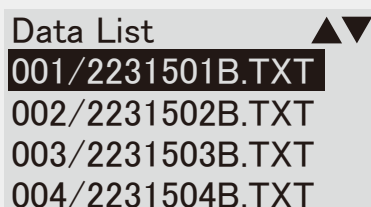
※ If there is no saved data, "No data found" is displayed.



Data List ▲▼
001/2231501B.TXT
 002/2231502B.TXT
 003/2231503B.TXT
 004/2231504B.TXT

- ③ Saved data are displayed as shown in the right. Scroll the data by  (UP SCROLL) /  (DOWN SCROLL) Keys.

※ Press  PRINT Key to print the displaying saved data. For details, see "PRINT OUT" in page 27.

※ Saved data is displayed in a current setting language of this instrument.
 (e.g.: If English is set now, every data saved in Japanese are displayed in English.)

※ The instrument displays this message when the system error occurs.

Stop test and format the removable disk in reference to "4. Formatting the Removable Disk" in page 59.

※ All of the saved data are deleted after formatting removable disk.



[BATTERY TEST]
 Good
 JIS
 55B24 ▼

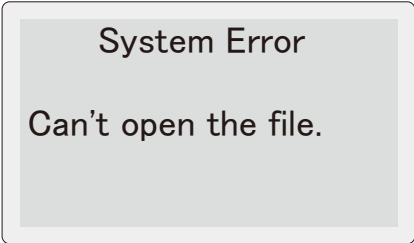

System Error
 Can't open the file.

MENU

3. Delete the Saved Data

Saved data can be deleted in the following procedures.

- ① Press **☰** (MENU) Key in "Choose the Test" screen (③ in page 16) or test result screens (⑨ in page 20 / ⑦ in page 25) to enter Menu screen.
Select "Delete Save Data" and press **↵** (ENTER) Key.

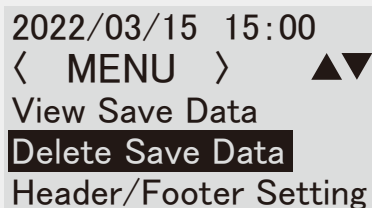

2022/03/15 15:00
< MENU > ▲▼
View Save Data
Delete Save Data
Header/Footer Setting

- ② Select the data to delete from the data list, and press **↵** (ENTER) Key.
※If there is no saved data, "No data found" is displayed.

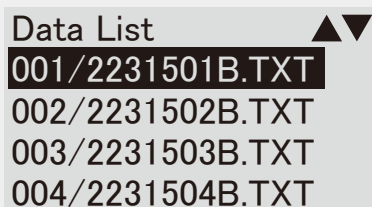

Data List ▲▼
001/2231501B.TXT
002/2231502B.TXT
003/2231503B.TXT
004/2231504B.TXT

- ③ Select "YES" and press **↵** (ENTER) Key to delete the test data.

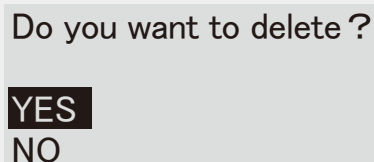

Do you want to delete ?
YES
NO

- ※When system error occurs, the message as shown in the right is displayed. Stop testing and format Removable Disk in reference to "4. Formatting the Removable Disk" in page 59.
※All saved data are deleted after formatting removable disk.

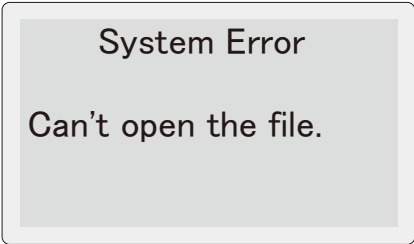

System Error
Can't open the file.

MENU

Refer to page 38 for the Header and Footer settings.

4. Test Count Display

You can see the test count history stored in the internal memory.

- ① Press  MENU Key when displaying the Battery Test screen (③ in page 16) or Test Result screen (⑨ in page 20, ⑦ in page 25) to open MENU screen.
Enter "View Test Current".

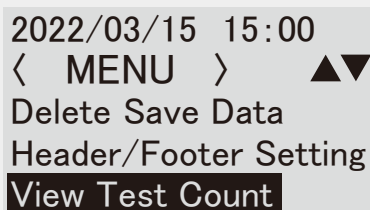

2022/03/15 15:00
< MENU > ▲▼
Delete Save Data
Header/Footer Setting
View Test Count

- ② Test count history is displayed on the screen.
(Deleted test counts are excluded.)

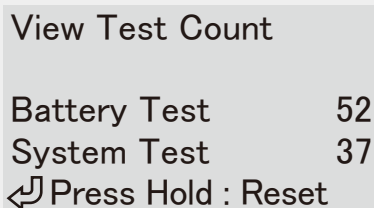

View Test Count
Battery Test 52
System Test 37
↶ Press Hold : Reset

■ Print Out

Press  PRINT Key to print out the Test Count Report.

Test Count Report

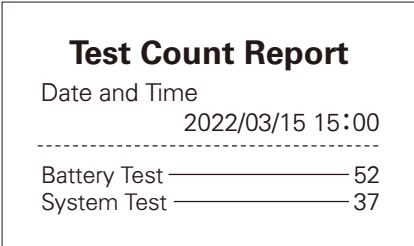

Date and Time
2022/03/15 15:00

Battery Test _____ 52
System Test _____ 37

■ Reset Test Count

Press and hold  Key to display the reset screen in the right.
Choose "YES" to delete the test count history.

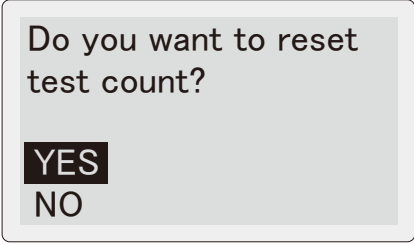

Do you want to reset
test count?

YES
NO

MENU

5. Date and Time Setting

① Press  (MENU) Key in "Choose the Test" screen (③ in page 16) or test result screens (⑨ in page 20 / ⑦ in page 25) to enter Menu screen.

Select "Date/Time Settings" and press  (ENTER) Key.

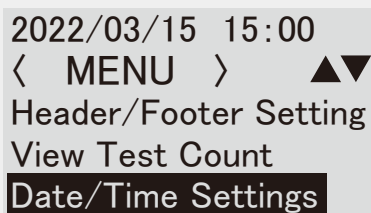



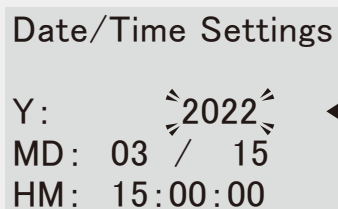

2022/03/15 15:00
 < MENU > ▲▼
 Header/Footer Setting
 View Test Count
Date/Time Settings

② Date/Time Setting screen is displayed.
 (Year (Y) is blinking)



Date/Time Settings
 Y: 2022
 MD: 03 / 15
 HM: 15:00:00

Year blinks.

③ Set "Year" with using  (UP SCROLL) /  (DOWN SCROLL) Keys and press  (ENTER) Key. Then "Month" starts to blink. Set "Month" and press  (ENTER) Key, Set the "Day" in the same way.

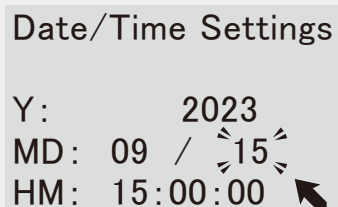

Date/Time Settings
 Y: 2023
 MD: 09 / 15
 HM: 15:00:00

The next setting blinks by pressing  (ENTER) Key.

④ Set Time (HM) until minute. Press  (ENTER) Key. Date/Time Settings are fixed with resetting "Second" to 00 and return to Menu Screen (previous Step ①).

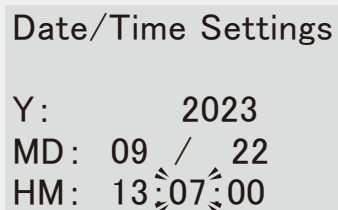



Date/Time Settings
 Y: 2023
 MD: 09 / 22
 HM: 13:07:00

Set until minute,
 then press  (ENTER) Key.

MENU

6. Language Setting

- ① Press  (MENU) Key in "Choose the Test" screen (③ in page 16).
Select "Select Language" and press  (ENTER) Key.

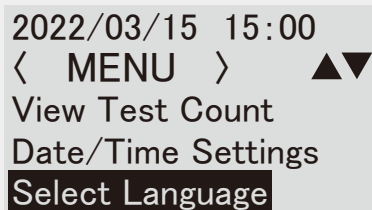



2022/03/15 15:00
< MENU > ▲▼
View Test Count
Date/Time Settings
Select Language

- ② Select preferred language and press  (ENTER) Key.
Language is fixed and return to Menu screen.





Language Selection
日本語
ENGLISH

7. Contrast Adjustment

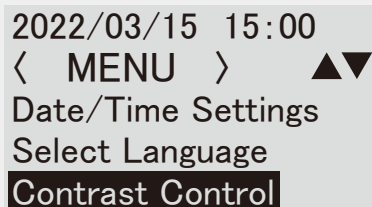
- ① Press  (MENU) Key in "Choose the Test" screen (③ in page 16) or test result screens (⑨ in page 20 / ⑦ in page 25) to enter Menu screen.
Select "Contrast Control" and press  (ENTER) Key.



2022/03/15 15:00
< MENU > ▲▼
Date/Time Settings
Select Language
Contrast Control

- ② Adjust LCD contrast in the range of 0 - 30 with  (UP SCROLL) /  (DOWN SCROLL) Keys.
Press  (ENTER) Key to fix the contrast and return to Menu screen.

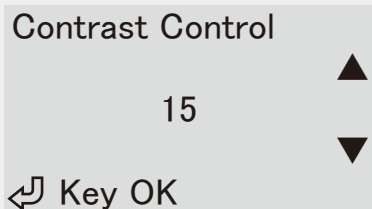

Contrast Control
15
▲▼
 Key OK

MENU

8. Temperature Setting

Set the battery temperature input mode in Battery Test.

Default setting is "Auto". You can change it to "Manual" if necessary.

- ① Press **MENU** (MENU) Key in "Choose the Test" screen (③ in page 16) to enter Menu screen. Select "Temperature Setting" and press **ENTER** (ENTER) Key.

2022/03/15 15:00
 < MENU > ▲▼
 Select Language
 Contrast Control
Temperature Setting

- ② Select "Manual" if you prefer to input the battery temperature manually in Battery Test (see page 20).

Press **ENTER** (ENTER) Key to return to Menu screen.

※Default setting is "Auto".

Temperature Setting
 Auto
Manual

9. Rated CCA Value Print

- ① You can select Print or Not Print the Rated CCA.

Press **MENU** (MENU) Key in "Choose the Test" screen (③ in page 16) to enter Menu screen. Select "Rated CCA Value Print" and press **ENTER** (ENTER) Key.

2022/03/15 15:00
 < MENU > ▲▼
 Contrast Control
 Temperature Setting
Rated CCA Value Print

- ② Select "No" if you do not print Rated CCA. Press **ENTER** (ENTER) Key, the screen returns to Menu screen.

※If "No" is selected, PC-saved data does not show Rated CCA also. Refer to page 45.

※This function is effective only for the battery chosen from installed battery list or its favorite.

Print / File Output
 the Rated CCA Value
YES
 NO

MAINTENANCE

1. Changing the Printer Paper

The instrument displays this screen when the printer paper is running out or unset. Set the new one in the following procedure.



- ① Pull up printer lever as shown in the right. printer cover lifts up.

※ **Do not pull up / open the printer lever or printer cover forcibly to avoid any damage to the instrument.**

- ② Open the printer cover and remove old printer paper.

- ③ Prepare the new paper.
Peel off the fixing seal, and put it into the printer compartment.
Be sure to put the inner side (printable side) to downward as shown in the right.

- ④ Pull the paper forward so that it extends past the serrated edge of the paper slot.

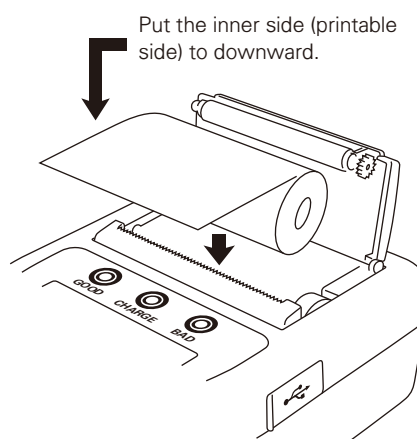
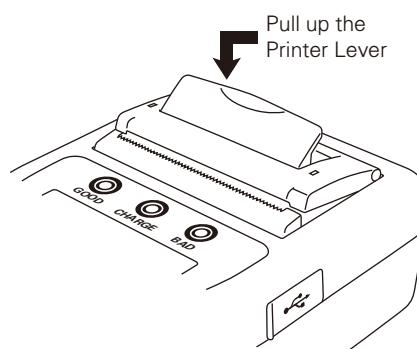

- Do not pull up / open the printer lever or printer cover forcibly to avoid any damage to the instrument.
- Be sure to put the printer paper facing the inner side (printable side) to downward. Cannot print on the reverse side.

MAINTENANCE

⑤ Close the printer lever, then close the printer cover with putting it over the pulled out paper. Cut off the extra paper.

※ Be sure to push the both ends of printer cover when closing. Pushing center part may damage the cover or the printer module.

Close the printer cover pushing both ends. (Do not push center part.)

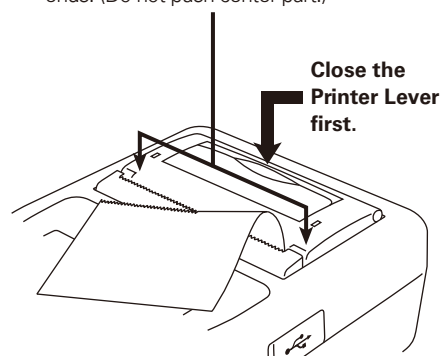

CAUTION

- To avoid any trouble or damage to the printer module, be sure to close the printer lever first when closing printer cover.
- Be sure to push the both ends of printer cover when closing. Pushing center part may damage the cover or the printer module.
- To prevent discoloration, do not place the printer paper under in any place where it will be subjected to direct sunlight or high temperatures / humidity.
- Keep this instrument in the supplied carrying case to avoid malfunction of the printer trouble by dust penetration.
- Be careful not to put the dust in the printer compartment to prevent any malfunction of the printer.
- Be sure not to reach the dust into the gear wheel part to prevent printer trouble.
- Do not keep this instrument in the dusty area to prevent printer trouble.
- Use genuine printer paper (model : 851). Using other paper could cause printing error or device failure.

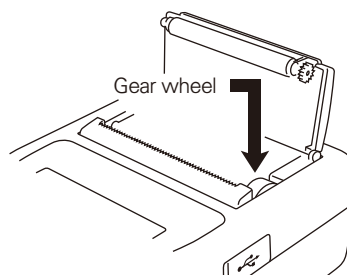

MAINTENANCE

2. Printhead Cleaning

Clean the printhead as per the below procedures, in case of faded printing error cause by dirty printhead.

- ① Open printer cover and remove printer paper.
※ See page 55 how to open printer cover.

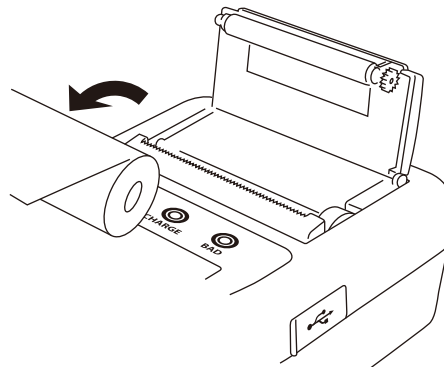

- ② Steep cotton swab in ethyl alcohol, and wipe the printhead.
If it is not enough, rub the printhead with cloth, applying ethyl alcohol on it.

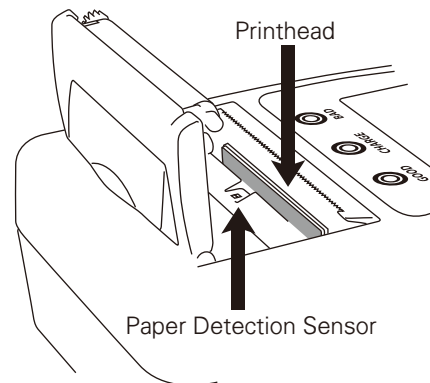

Cleaning Paper Detection Sensor:
Use dry cotton swab to wipe off without using ethyl alcohol.



CAUTION

- Do not wipe / rub the printhead strongly. This may hurt printhead or cause printing error.
- Do not use methyl alcohol, toxic to humans.
- Do not use any sharp or hard materials for printhead cleaning.

MAINTENANCE

3. Changing Battery Cable

You can replace the Battery Cable at your side in case of damaging the battery clip or cable.
(Model No. 800 Battery Cable)

① Loosen the screw on the back of the cable connector.

② Pull out the connector from the unit.

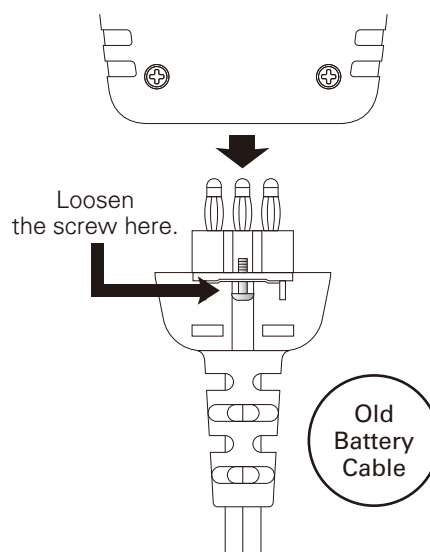

③ Insert the new Battery Cable deeply into the unit. Tighten the screw.

※ Insert the battery cable deeply into the unit, and fix the screw tightly. Loose connection may cause the measurement failure.

※ Keep clean the battery cable, connection plugs, and terminals. Dusts may cause the contact failure.

※ Do not connect battery cable oppositely. This may damage the unit and the cable.

※ Do not tighten the battery cable screw too strongly. This may damage the screw or contact part of the unit, and makes them unfixable.

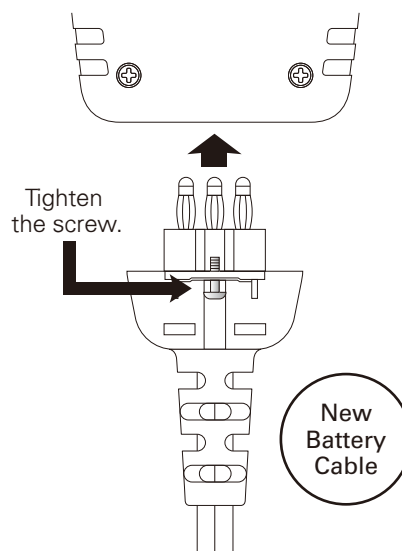



MAINTENANCE

4. Formatting the Removable Disk



CAUTION

- All of the saved data are deleted after formatting removable disk.

- ① Connect the instrument to car battery (see page 15) or PC (see page 44) holding down  (ENTER),  (FAVORITS), and  (PRINT) Keys. The instrument turns on.

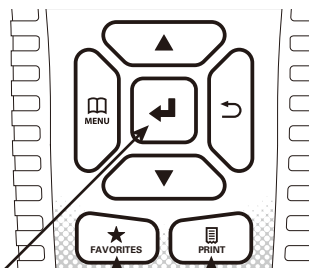

Hold down 3 keys.

- ② The instrument displays this message.
Press  (ENTER) Key to start formatting the removable disk.
- ※ Turn off the instrument to quit the formatting.
 - ※ The instrument also displays this screen when removable disk has an error. In this case, format the disk in the same way.
 - ※ Do not turn off the instruments during the disk formatting is proceeding.

Disk Formatting ?

YES - ENTER
NO - restart

- ③ Instrument restarts automatically after completing the disk formatting.

MAINTENANCE

5. DMP Folder

When measurement error occurs during the battery test process, the instrument creates DMP folder in the removable disk to save the internal error data.

You do not need to delete this.

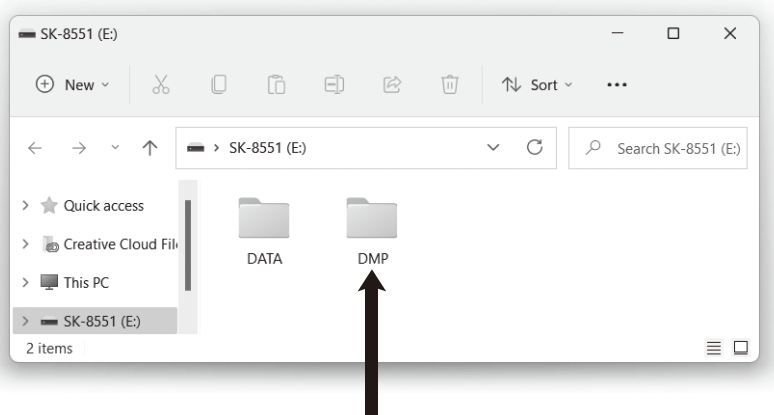

DMP Folder

6. Periodical Check and Calibration

Periodical check and calibration is necessary to make safety measurements and to maintain the specified accuracy. The recommended check and calibration term is once a year and after the repair service. This service is available at KAISE AUTHORIZED SERVICE AGENCY through your local dealer.

7. Software Version Update

- You can update the internal software from our website (<https://www.kaise.com/NewEnglish.htm>) when it is available. Download the file in reference to the loading procedures.

8. Others

- If the metal part of the battery clip is soiled, wipe it off with soft cloth to obtain the accurate measurement.
- If Date and Time are not able to set, internal backup battery is exhausted. Ask KAISE AUTHORIZED SERVICE AGENCY through your local dealer for repair service.

TROUBLE SHOOTING & REPAIR

If there are any failure with this instrument, check the following trouble shoots before asking repair service. Ask KAISE CORPORATION AUTHORIZED SERVICE AGENCY through your local dealer when there are any questions or troubles with this instrument.

Symptoms	Possible Causes and Necessary Treatments
<p>Cannot turn on the instrument</p>	<ul style="list-style-type: none"> • Battery Clips are connected in the wrong polarity. → Connect Black clip to minus ⊖, and red clip to plus ⊕ battery terminals. • Battery voltage goes down to 8V or lower. → Recharge the battery. • Weak connecting of battery cable or USB cable. → Insert their plugs deeply. • Metal parts of battery clips or battery terminals have problems. → Make them clean and check if there are not damaged. • Battery cable is damaged (disconnected). → Replace with the new battery cable.
<p>Cannot save, view and delete data</p>	<ul style="list-style-type: none"> • System error is occurring. → Format the Removable Disk in reference to "4. Formatting the Removable Disk" in page 59.
<p>Instrument freezes with English letters on LCD</p>	<ul style="list-style-type: none"> • There is an error in removable disk. → Format the disk in reference to "4. Formatting the Removable Disk" in page 59.
<p>Date / Time are not saved</p>	<ul style="list-style-type: none"> • Backup battery (built-in) is exhausted. → Ask KAISE AUTHORIZED SERVICE AGENCY through your local dealer for repair service.
<p>LCD displays Measurement Error</p>	<ul style="list-style-type: none"> • Metal part of the battery clip or battery terminal is soiled. → Remove it cleanly. • There in an abnormality in the battery. → Check visually the appearance of the battery; dirt of the terminal, abnormality of the terminal cable, etc. • Battery cable is damaged (disconnected). → Replace with the new battery cable.

TROUBLE SHOOTING & REPAIR	
Symptoms	Possible Causes and Necessary Treatments
Screen shows "Disk Error ..."	<ul style="list-style-type: none"> • The instrument has system error. → Format the disk in reference to "4. Formatting the Removable Disk" in page 59.
Wrong test results	<ul style="list-style-type: none"> • Weak connection between battery clips and battery terminals. → Check battery clips to touch their metal serrated parts on both black and red battery terminals.
Faded printing	<ul style="list-style-type: none"> • Printhead becomes dirty. → Clean the printhead as per procedures in page 57. → Use genuine printer paper (model : 851).
Printer does not work	<ul style="list-style-type: none"> • Printer paper is set in reverse. → Place the paper correctly in reference to "1. Changing the Printer Paper" in page 55. • Printer is jammed. → Open printer cover and pull out the printer paper. • Wrong printer paper is using. → Use genuine printer paper (model : 851). • Paper detection sensor is dirty. (Screen shows "Paper out..." even if printer paper remains enough.) → Wipe off paper detection sensor by cotton swab (refer to page 57).
Not recognized by PC	<ul style="list-style-type: none"> • Removable disk in this instrument is damaged. → Format the removable disk. (Refer to "4. Formatting the Removable Disk" in page 59) • Poor compatibility with your PC. → Use USB hub to connect with PC.

ABOUT KAISE WEBSITE

1. SK-8551 Product Page

Product information, Data sheet (PDF), Instruction manual (PDF), and Technical information (PDF) are available.

SK-8551 Product Page URL
https://www.kaise.com/e_car_sk8551.html



You can also access through:

Kaise Website (<https://www.kaise.com/NewEnglish.htm>) → Products → Automotive Testers
→ SK-8551 Battery Checker

2. SK-8551 User Login Page

You can download "Header/Footer Editor Application" and template images.

SK-8551 User Login URL
https://www.kaise.com/sk8551ex/e_car_sk8551ex.html



You can also access through: SK-8551 Product page → "User Login" banner

WARRANTY

SK-8551 is warranted in its entirety against any defects of material or workmanship under normal use and service within a period of one year from the date of purchase of the original purchaser. Warranty service is available at **KAISE AUTHORIZED SERVICE AGENCY** through your local dealer. Their obligation under this warranty is limited to repairing or replacing SK-8551 returned intact or in warrantable defect with proof of purchase and transport charges prepaid. **KAISE AUTHORIZED DEALER** and the manufacturer, **KAISE CORPORATION**, shall not be liable for any consequential damages, loss or otherwise. The foregoing warranty is exclusive and in lieu of all other warranties including any warranty of merchantability, whether expressed or implied.

This warranty shall not apply to any instrument or other article of equipment which shall have been repaired or altered outside of **KAISE AUTHORIZED SERVICE AGENCY**, nor which have been subject to misuse, negligence, accident, incorrect repair by users, or any installation or use not in accordance with instructions provided by the manufacturer.

SK-8551 取扱説明書(英文)_表3



KAISE AUTHORIZED DEALER

kaise

KAISE CORPORATION

422 Hayashinogo, Ueda City, Nagano Pref., 386-0156 Japan
TEL : +81-268-35-1601 / FAX : +81-268-35-1603
E-mail : sales@kaise.com
<https://www.kaise.com>

Product specifications and appearance are subject to change without notice due to continual improvements.