

kaise

BATTERY CHECKER

Instruction Manual

SK-8536



KAISE CORPORATION

Thank you for purchasing "SK-8536 BATTERY CHECKER". To obtain the maximum performance of this instrument, read this Instruction Manual carefully, and take safe measurement.

CONTENTS

SAFETY PRECAUTIONS	1-3
OPERATING PRECAUTIONS	4
FEATURES	5
UNPACKING AND INSPECTION	6
NAME ILLUSTRATION	7-8
SPECIFICATIONS	
1. General Specifications	9
2. Measurement Specifications	9
BEFORE USE	
1. Technical Words	10-11
2. Language / Date & Time Settings	11
3. Others	11
BATTERY TEST	12-20
SYSTEM TEST	21-24
PC CONNECTION	25-26
MENU	
1. Print Out	27-29
2. Save the Test Result	30-31
3. View the Saved Data	32
4. Delete the Saved Data	33
5. Date and Time Setting	34
6. Language Setting	35
7. Contrast Adjustment	35
8. Temperature Setting	36
9. Rated CCA Value Print	36
MAINTENANCE	
1. Changing the Printer Paper	37-38
2. Printhead Cleaning	39
3. Formatting the Removable Disk	40
4. DMP Folder	41
5. Periodical Check and Calibration	41
6. Software Version Update	41
7. Others	41
TROUBLE SHOOTING & REPAIR	42-43
ABOUT KAISE WEBSITE	
1. SK-8536 Product Page	44
WARRANTY	45

SAFETY PRECAUTIONS (strict observance is required)

This instruction manual contains the important contents to prevent harm to user or others and damage of property, and to use the instrument safely and correctly. Read this manual carefully and obey the contents after having understand the following terms and symbols.

■ Following symbols in this manual describe the harm and damage that would be caused by incorrect ueage.



WARNING

This symbol in this manual advises the user of an electrical shock hazard that could result in serious injury or even death.



CAUTION

This symbol in this manual advises the user of an electrical shock hazard that could cause injury or material damages.

■ Caution marks that require your attention (equivalent marks have the same meanings.)



This symbol shows the warnings and cautions.



This symbol shows the prohibited matters.



This symbol shows the matters that is forced to do.

SAFETY PRECAUTIONS (strict observance is required)

WARNING

Take the measurement under well-ventilated environment.

The hydrogen gas which stayed around battery catches fire from the spark that occurred when connecting the Battery Clips and might explode.



Make sure that the shift lever is set to "Parking" position (set to "Neutral" for stick shift vehicle).

The vehicle runs accidentally and could cause unexpected accident, electric shock, fire or damage to the instrument / vehicle.



Make sure that the parking brake is applied.

The vehicle runs accidentally and could cause unexpected accident, electric shock, fire or damage to the instrument / vehicle.



Keep the instrument away from babies or children.

Important to prevent any accident, injury, or electric shock hazard.



Do not use this instrument with the hands or Battery Clips wetting.

Accident, electric shock, fire, or damage to the instrument / vehicle may occur.



Do not take the measurement around inflammables such as gasoline or oil.

Fire or explosion may occur.



Do not take the measurement for the battery which does not have enough battery fluid.

It causes combustion and the explosion of the battery.



Do not drive the vehicle keeping the instrument connected.

Accident, electric shock, fire, or damage to the instrument / vehicle may occur.



Do not work in the dark place.

Accident, electric shock, fire, or damage to the instrument / vehicle may occur.



Do not get the instrument wet.

Fire or electric shock may occur.



Do not use the faulty instrument that can recognize such as display trouble, switch failure.

Stop using the instrument immediately and consult with your local dealer. Using the faulty instrument may cause the unexpected accident, fire, or electric shock.



Do not touch the USB port with finger or insert the foreign objects in the USB port.

Accident, electric shock, fire, or damage to the instrument may occur.



Do not place this instrument in any place where it will be subjected to direct sunlight, high temperatures or the inside of the sun-heated vehicles.

Fire, electric shock or damage to the instrument may occur.



Do not touch the heated part of the engine such as exhausting parts.

Important to prevent burn injury.



SAFETY PRECAUTIONS (strict observance is required)

WARNING

Be careful about your hands, gloves and clothes not to be caught in the engine belt or cooling fan.

Important to prevent injury.



Do not use the instrument if it is in the abnormal condition.

Stop using the instrument immediately and consult with your local dealer when recognizing smoke, strange smell, or abnormal noise.

Using the faulty instrument may cause the accident, fire, or electric shock.



Do not attempt to disassemble or modify the instrument.

Fire, electric shock, or damage to the instrument may occur.



Do not use the cables with which coating were damaged.

Fire or electric shock may occur.



CAUTION

Be careful not to get the battery fluid into eyes or not to attach it to skin and clothes.

Loss of eyesight or injury may occur. If it gets into eyes, rinse immediately and submit to medical treatment.



Be careful not to jam the fingers in the Battery Clip.

It causes injury.



Be careful about the instrument or the cables not to be caught in the engine belt or cooling fan.

Short circuit or wire breaking may occur that could cause unexpected accident, electric shock, or damage to the instrument / vehicle.



Be careful about the instrument or the cables not to touch the heated part of the engine such as exhausting parts.

Important to prevent any accident, or damage to the instrument / vehicle.



Connect the Battery Clips to the battery with the correct polarity.

Reverse connection causes damage to the instrument.



When testing the battery on vehicle, take the measurement after stopping the engine and turning off the power supply of all in-vehicle apparatuses.

It causes injury or damage to the instrument.



Disconnect this instrument from battery soon after finishing the test.

It causes consumption of the battery and the ignition.



Do not hit, thrust and make scratch on the LCD display part.

It causes trouble or damage to the LCD.



Do not use the other USB cable except the supplied one.

Damage to the instrument or PC may occur.



OPERATING PRECAUTIONS

- Do not apply the engine oil to the metal part of the Battery Clips or USB Plug to prevent contact failure.
- Do not apply engine oil, gasoline, antifreeze or battery fluid to the instrument to prevent any damage on its surface.
- Do not polish the case with the fluid that contains alcohol to prevent the cracking.
- Use this instrument under the environment of -10°C to 50°C, 80%RH or less to obtain the accurate measurement. (Printer is operating at 0°C to 50°C)
- Cables which coating are heat damaged might cause the short circuit. Do not use them and replace into the new ones.
- Disconnect this instrument from battery soon after finishing the test to prevent trouble of this instrument and running out of battery power.
- Do not touch the inside of the printer with finger to prevent trouble of this instrument.
- Do not put serious pressure on Printer Lever or Printer Cover to prevent trouble or damage to this instrument.
- If Date and Time are not able to set, built-in battery for backup is exhausted. Ask KAISE AUTHORIZED SERVICE AGENCY through your local dealer for repair service.
- Keep this instrument in supplied Carrying Case to avoid malfunction of the printer trouble by dust penetration.
- Use genuine printer paper (model : 851). Using other paper could cause printing error or device failure.

Cautions for Handling

- **Do not apply mechanical shock.**
The shock such as dropping or beating might damage the instrument and may cause the trouble.
- **Do not pull cables forcibly.**
Pulling the cables forcibly, such as when removing the Battery Clips from the battery or USB Plugs from USB Port, may cause trouble such as the breaking of wire.

Cautions for Safekeeping

- **Keep away the instrument from the following place.**
 - Dusty area
 - The place where has the water splash
 - The place where applies the hard shock
 - -20°C or less, 60°C or more, 70%RH or more
 - The place where has the condensation
 - The place where is exposed to direct sunlight

FEATURES

- SK-8536 can test State of Charge (SOC), State of Health (SOH), Start Performance and Charging System of the car battery.

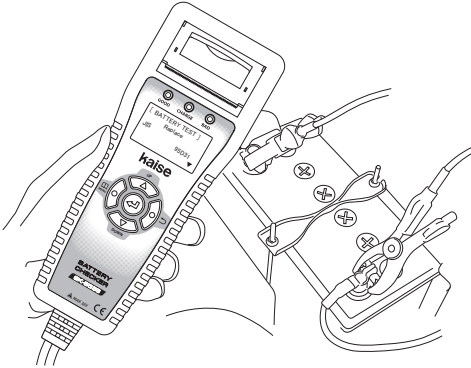

- Auxiliary battery for hybrid car is testable.
- Portable instrument that can operate with one hand.

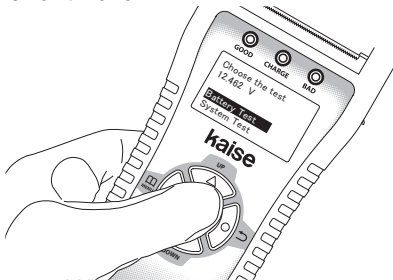

- Capable of saving the test results up to 359 data. Moreover, the test data can edit on PC as text data by using the supplied USB cable.

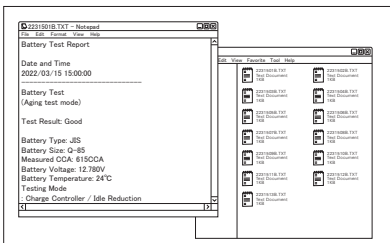

- Batteries for the vehicle equipped with charge control system or idle reduction system are testable.

- Test result can be printed on site by built-in printer. English or Japanese selectable.

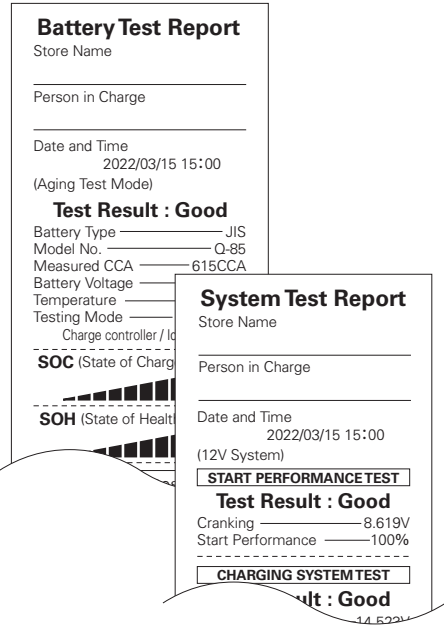

- The software is upgradeable by connecting supplied USB cable with PC.(※)

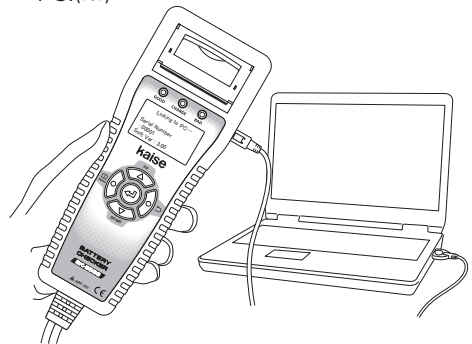

※PC with Internet access is necessary.

UNPACKING AND INSPECTION (Check before use)

Confirm if the following items are contained in the package in good condition.
If there are any damages or missing items, ask your local dealer for replacement.

① Battery Checker...1 pce.

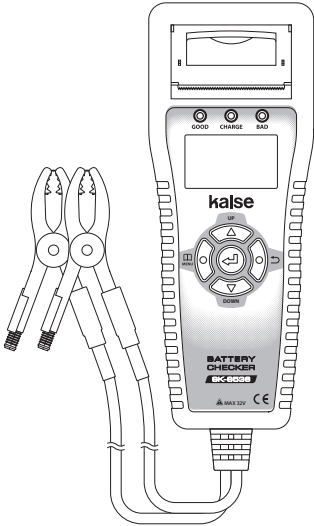

② USB Cable (934)...1 pce.



③ Printer Paper...2 rolls
(installed, and spare)

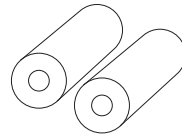

④ Carrying Case...1 pce.

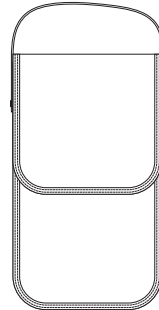

⑤ Instruction Manual...1 pce.

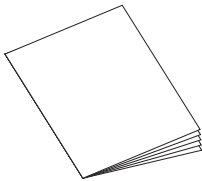

※If Date and Time are not able to set,
internal backup battery is exhausted.
Ask KAISE AUTHORIZED SERVICE
AGENCY through your local dealer for
repair service.

※The following desiccant is
enclosed in the package
for maintenance of quality.
Throw it away after
opening the package.



Available Printer Paper (10pcs per set)

- Parts number : 851
- Paper width : approx. 57mm,
- length : approx. 5.8m
- Paper life per 1 roll
Battery test : Approx. 50 tests
System test : Approx. 55 tests

Wire Brush

- Parts number : 690
For battery terminal cleaning (3pcs).

NAME ILLUSTRATION

Front Side

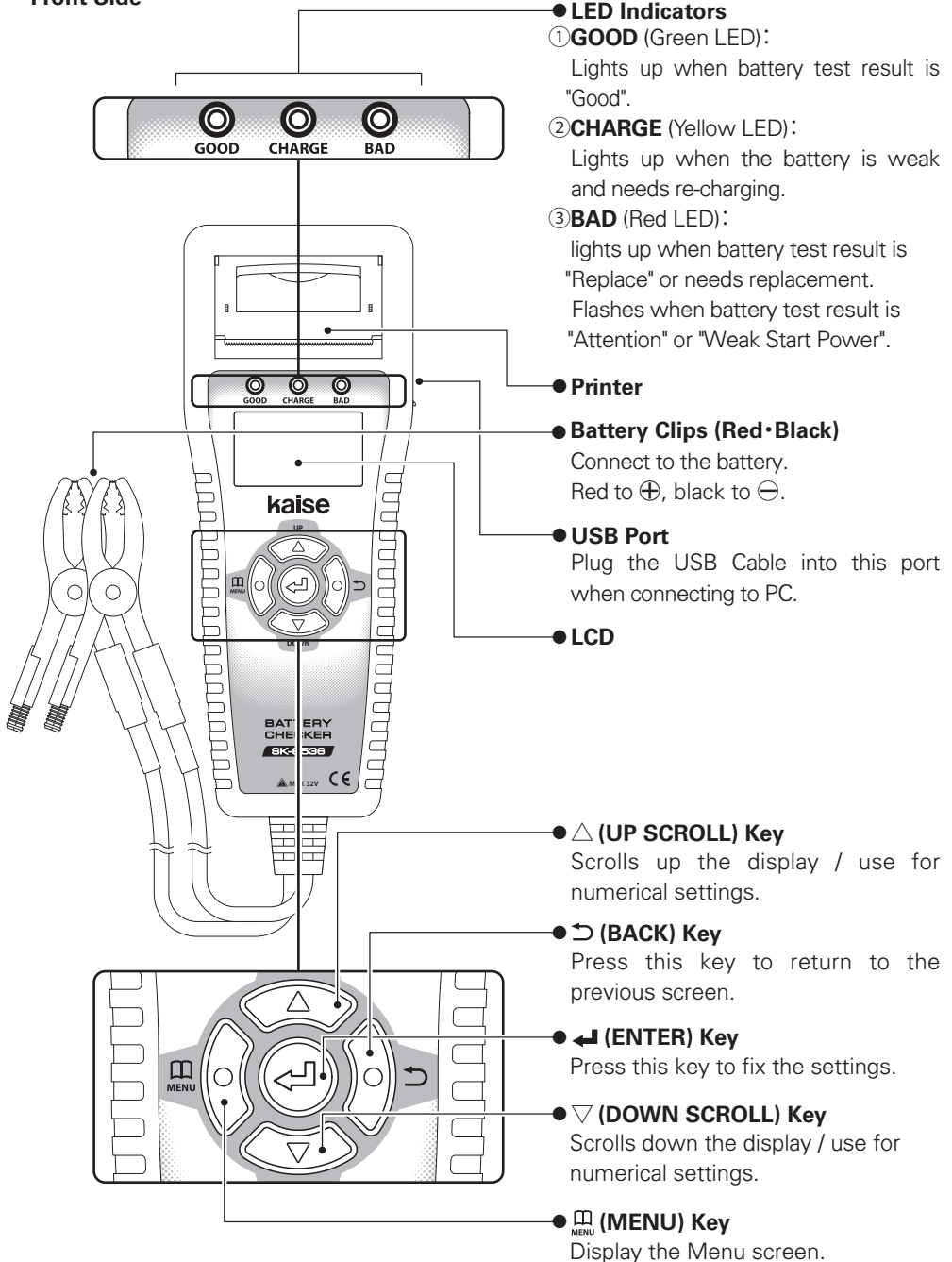

● LED Indicators

① GOOD (Green LED):

Lights up when battery test result is "Good".

② CHARGE (Yellow LED):

Lights up when the battery is weak and needs re-charging.

③ BAD (Red LED):

lights up when battery test result is "Replace" or needs replacement.
Flashes when battery test result is "Attention" or "Weak Start Power".

● Printer

● Battery Clips (Red·Black)

Connect to the battery.
Red to ⊕, black to ⊖.

● USB Port

Plug the USB Cable into this port when connecting to PC.

● LCD

● △ (UP SCROLL) Key

Scrolls up the display / use for numerical settings.

● ↶ (BACK) Key

Press this key to return to the previous screen.

● ↵ (ENTER) Key

Press this key to fix the settings.

● ▽ (DOWN SCROLL) Key

Scrolls down the display / use for numerical settings.

● ☰ (MENU) Key

Display the Menu screen.

NAME ILLUSTRATION

Rear Side

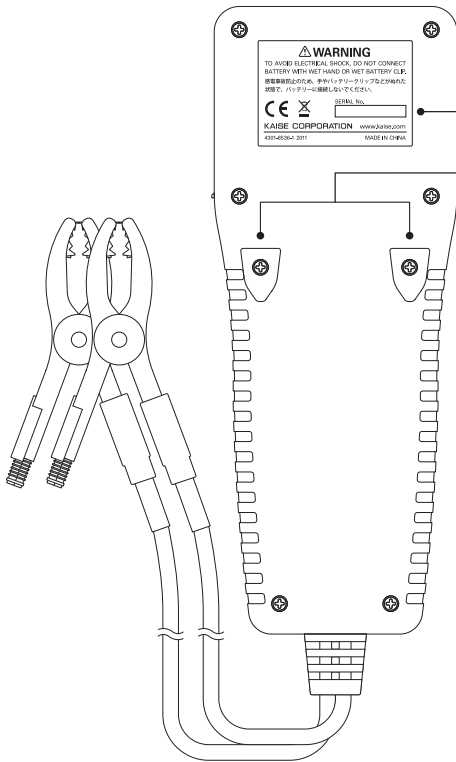

● Serial Number

● Battery Clip Holder
Clip Battery Clips here when not in use.

How to clip :

Open the battery clip widely and clip it to the holder in the plastic part of the clip. (Do not clip in the metal part)

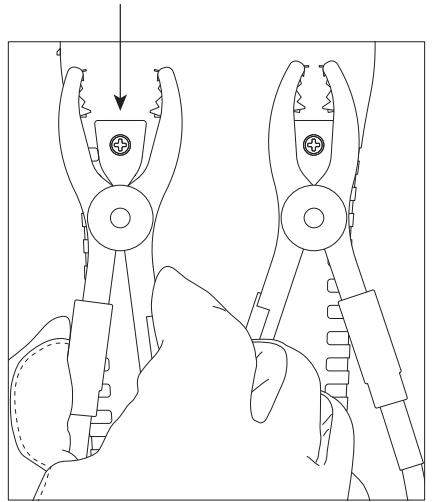

CAUTION

- Do not clip in the metal part of the Battery clip. To prevent any damages of the Battery Clip and Clip Holder.

SPECIFICATIONS

1. General Specifications

1. Lcd	Dot presentation, 128×64dots
2. Language	English, Japanese (Default: English)
3. Display Rate Of Voltage Measurement	1 time/second
4. Led Indication	Green: Lights up when battery test result is "Good" Yellow: Lights up when battery is weak and needs re-charging Red: Lights up when battery test result is "Replace" Flashes when battery test result is "Attention" or "Weak Start Power"
5. Printer	Built-in
6. Battery Cable Length	Approx.70cm (Clip and Bush are not included)
7. Power Supply	Testing battery or USB connection
8. Testing Voltage	DC8V to 32V (Testing battery), DC5V (USB Connection)
9. Testable Batteries	12V lead batteries ※For 24V battery, only Start-up Performance Test or Charging System Test are possible.
10. Testable Battery Standards	JIS, SBA, DIN, EN, SAE, BCI, CCA and Industrial Rating
11. Testable Battery Performance	CCA: 100 to 1400, Industrial Rating: 1.0mΩ to 50.0mΩ
12. Measurable Tests	12V battery : Battery Test / Start Performance Test and Charging System Test 24V battery : Start Performance Test and Charging System Test
13. Temperature Coefficient For Voltage Measurement	Accuracy at 23°C±5°C×0.01/°C
14. Data Saving	Test results can be saved to the internal memory up to 359 data. ※The data can be sent to PC via USB connection
15. Software Update	From web site via USB connection
16. Operating Temperature & Humidity	-10°C to 50°C, less than 80%RH (in non-condensing)
17. Storage Temperature & Humidity	-20°C to 60°C, less than 70%RH (in non-condensing)
18. Safety Level	CE marking approved EN61326-1, EN61010-1
19. Dimension	248mm(H)×96mm(W)×50mm(D) ※Cable and Bush are not included
20. Weight	Approx. 550g ※Printer paper is not included

※Specification and appearance are subject to change without notice.

2. Measurement Specifications (23°C±5°C, <80%RH in non-condensing)

Battery Voltage

Range	Accuracy	Resolution	Maximum Input
16.000V	(8V to 16V): ±0.15%±3dgt	1mV	Lower than 32V
32.000V	(16V~32V): ±0.15%±3dgt		

※Overload indication : "Over voltage" is displayed.

Temperature

Range	Accuracy	Resolution	Maximum Input
-20°C to 60°C	±3°C	1°C	-20°C to 60°C

※Accuracy is applied when measuring after leaving under constant temperature more than an hour.

BEFORE USE

1. Technical Words

• What is CCA?

CCA stands for Cold Cranking Amperes. It is defined as the current a battery at 0°F (-18°C) can discharge for 30 seconds and maintain 7.2V or more (for JIS, SAE and BCI). And it is defined as the current a battery at 0°F (-18°C) can discharge for 10 seconds and maintain 7.5V or more (for EN and DIN). The battery which has the bigger CCA, the higher ability to start an engine, CCA is one of the criterion for selection of the battery.

There are two CCA definition groups, JIS/SAE/BCI and SBA/EN/DIN, as in the below table.

CCA definition of various standards

Standards	CCA Definition	Countries
JIS	The current discharge at 0°F (-18°C) for 30 seconds and maintain 7.2V or more.	Japan
SAE		USA
BCI		USA
SBA S0102	The current discharge at 0°F (-18°C) for 10 seconds and maintain 7.5V or more.	Japan
EN		EU
DIN		Germany

※Former DIN standard is out of specification.

• What is SOH (State of Health)?

SOH is the health condition of the battery, the state is expressed in percentage (%).

Definition of SOH in this product:

SK-8536 defines SOH 30% as the threshold of the battery replacement recommendation.

Test result shows "Replacement is necessary" when measured SOH is 30% or less and test result of SOC is not "Charge/Retest".

※SOH(%) is calculated as the ratio of CCA standard value to CCA measured value.

※SOH(%) fluctuates due to the rate of deterioration and charging condition.

• What is SOC (State of Charge)?

SOC is the charging condition of the battery, the state is expressed in percentage (%).

Definition of SOC in this product:

SK-8536 defines as SOC 100% when the battery voltage is higher than 12.756V. (Higher than 13.056V for the battery for industry)

※SK-8536 does not show the exact measurement voltage when testing the battery just after an engine shutdown or just after charging. Test the battery after reducing the stimulated condition according to the procedure mentioned in page 12.

BEFORE USE

• What is Ripple Voltage?

Ripple Voltage is the feeble change of charging voltage which occurs when rectifying the generated voltage by diode. If diode is damaged, the ripple voltage fluctuated sharply and adversely affects battery and in-vehicle apparatus.

2. Language / Date & Time Settings

- Set date and time before using this instrument. (Refer to "5. Date and Time Setting" in page 53).
- Language changeable from English (default setting) to Japanese. (Refer to "6. Language Setting" in page 35).

3. Others

- Protection film is put on the front plate of the unit before shipment. Tear off the protection film before using this instrument.

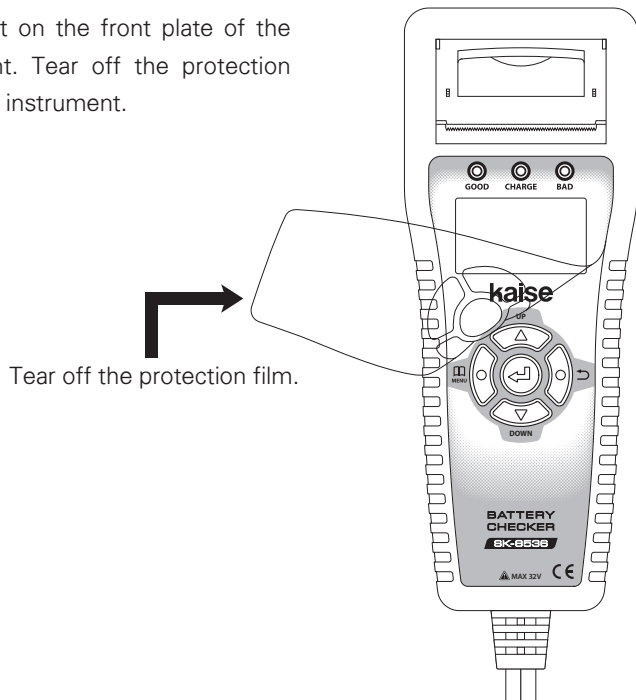

Initial display shows the factory default settings.

CAUTION

- This instrument forced to be restarted if the testing battery is extremely exhausted and cannot afford to supply the workable current.
- Test the battery in the state of the engine shutdown to obtain the accurate measurement.
- When testing 24V battery, test each 12V battery which is connected in series.
- When testing the battery on vehicle, test the parked car after turning off the power supply of all in-vehicle apparatuses which are using the electricity from battery and locking the car door to obtain the accurate measurement.
- Test result may change when testing the same battery repeatedly. Also, test result may change when testing the weak battery after using the printer.
- Test result may change, even when testing the same battery, depending on the battery condition or change the storage environment.
- Test results may be higher than usual just after driving. When testing the battery test of such a car, test it after doing the following procedure.
 - Turn on the headlights for approx. 20 seconds.
 - Turn off the headlights and test it more than 3 minutes after turning off the headlights.

In case of the test result is "Charge/Retest" by turning on the headlights, shorten the time of turning on the headlights after re-charging the battery, and lengthen the time of intervals before testing.

When you do not perform the procedure mentioned above or testing battery unit just after charging, test after an interval more than 2 hours.

- This instrument judges the battery condition with testing the basic use of the lead battery such as charge-discharge characteristics. Test result is not for judging whether the special control function can use for the vehicle or not.
- This instrument is for testing fundamental battery performance, charging and discharging ability, but not for judging the capability of actuating the special control function such as idle reduction system. For the batteries working with such functions, charging ability may be weakened in its using process. When the relevant functions cannot be activated, check the system details in the maintenance manual of the vehicle.
- The maximum CCA displayed with this unit is up to 1400CCA.

BATTERY TEST

Test Preparation

- Make visual inspection for the battery to be tested before connecting battery clips to the battery terminals.
- Replace the battery terminals if there is corrosion or crack occurs on the terminals.
- Connect the battery clips to the battery terminals tightly without loosening.
- Clean up the battery terminals and battery clips if there is greasy dirt.
- Do not test the battery which has any damages on its body or terminals. Replace immediately.
- As for the battery which battery fluid almost decreases to LOWER line, refill the purified water and make auxiliary charging.
- Replace the battery which battery fluid is discolored and decreases under the LOWER line.
- Check visually, if there is anything wrong with battery cable and clips.

Test the SOC (State of Charge) and SOH (State of Health) of the battery.

- ① Connect Black and Red battery clips to minus \ominus and plus \oplus battery terminals.

Make sure to touch metal serrated parts on both terminals.

- ※ Connect them to the nearest part of the terminals is acceptable if the clips cannot catch the battery terminals.

In this case, CCA may be measured lower than the actual value.

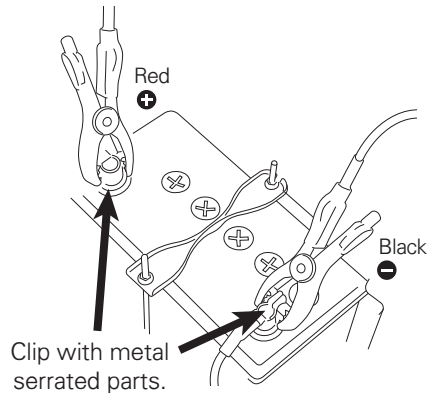

CAUTION

- Make sure to connect the battery clips tightly to battery terminals to obtain the accurate measurement.
- Connect battery clips touching metal serrated parts on battery terminals. Measurement should be incorrect if any one side is non-contacted.
- Clean up the battery terminals and the battery clips before testing to obtain the accurate measurement.

BATTERY TEST

②The instrument turns on automatically and enters "Choose the test" screen (step ③) after displaying the model number / software version number.

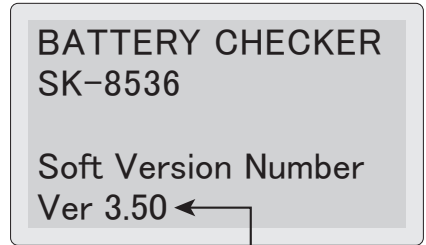

Current version number

※Perform "3. Formatting the Removable Disk" in page 40 when display shows this error message.

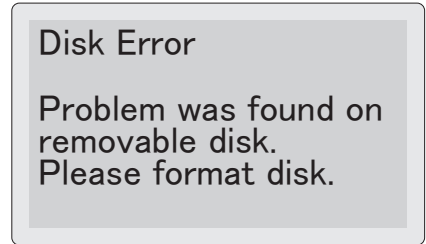

③Select Battery Test, press **↵** (ENTER) Key.

※Display shows the connected battery voltage.

●  (MENU) Key :

Move to MENU screen. (see page 27)

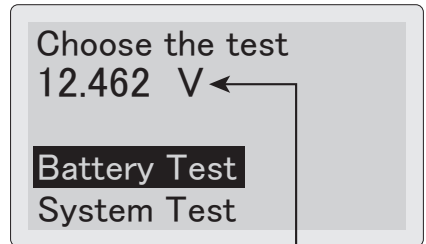

Battery voltage

BATTERY TEST

④ Select the battery type to be tested. Select the battery type, and press **↵** (ENTER) Key.

※ Battery list : enables to choose battery models, such as JIS / SBA standards from the list.

※ Battery test does not work when the battery voltage is higher than 13.3V. LCD shows WARNING. (13.6V for industrial battery)

※ When the battery voltage is higher than 16V, LCD shows "OVER VOLTAGE" warning.

※ When testing the batteries for industrial, golf cart, leisure boat, or deep-cycle, select "Input CCA" if the CCA is shown on the battery. Otherwise, choose "Industry".

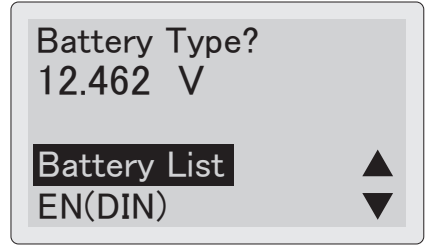

⑤ Select testing mode.

Select "Standard" for normal batteries.

Select "Charge Controller / Idle Reduction" when testing following batteries ;

- Charge control / idle reduction compatible batteries
- Batteries in Charge control / idle reduction vehicles

※ LCD shows "Industrial Rating" screen when selecting "Industry" in display ④ .

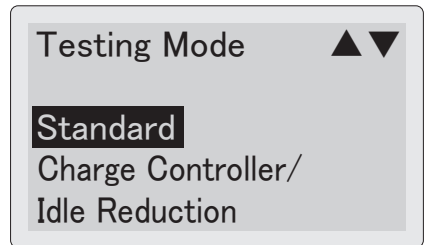

- When testing the auxiliary battery for hybrid car, select "Hybrid Auxiliary" and press **↵** (ENTER) Key.

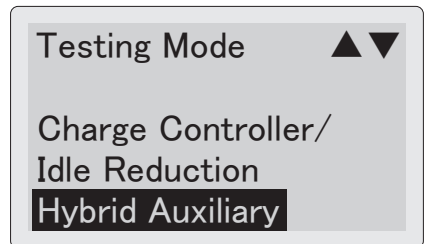

⑥ Select Test Mode.

Aging Test :
for deterioration check.

Unused Battery Test :
for condition check of unused battery

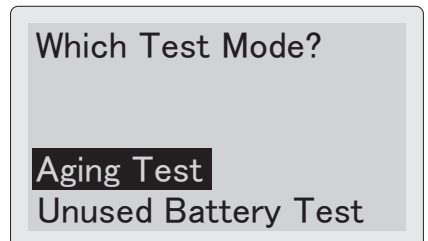

BATTERY TEST

⑦The following screen is displayed depending on the selected battery standards.

• When select Battery List

Select the test-battery group from the list, and press **↵** (ENTER) Key.

The list is classified by battery size or functions such as idle reduction, EN for Japanese cars or hybrid auxiliary.

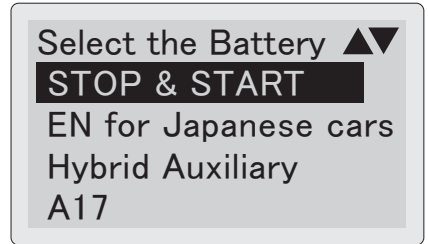

Select battery number to be tested.

Press **↵** (ENTER) Key to start battery test.

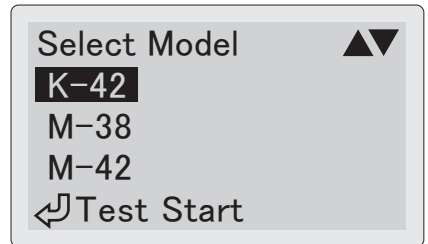

※Selected battery standard is retained.

※If knowing only battery size like B24, D31, etc., select JIS of the greatest specifications which is replaceable.

• "EN(DIN)" / "SAE(BCI)" / "CCA input"

Input the CCA rating using **△**(UP SCROLL) / **▽** (DOWN SCROLL) Keys.

Press **↵** (ENTER) Key to start battery test.

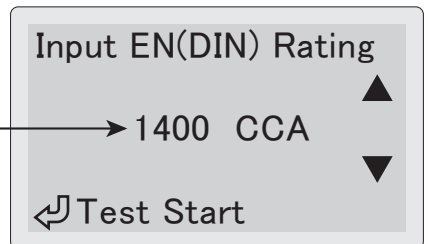

※Selected battery rating is retained.

Input CCA rating

※CCA value list for each battery manufacturers and their battery models is available on KAISE website.

BATTERY TEST

• "Industry"

Select "YES" if you can input the industrial rating (internal resistance $m\Omega$) and press \leftarrow (ENTER) Key.

When choosing "NO", battery test starts.

※Battery condition (good / bad) is not tested when choosing "NO".



- Remove the all electric loads connected to the battery to be tested to obtain the accurate measurement.
- Battery test is effective for only 12V lead battery.
- Generally, industrial battery is recommended to be replaced when the internal resistance comes up to double of the unused battery. Based on this, SK-8536 judges "Bad" when the test result becomes double of the input industrial rating.

(When selecting "YES")

Input $m\Omega$ value with using Δ (UP SCROLL) / ∇ (DOWN SCROLL) Keys.

Press \leftarrow (ENTER) Key to start battery test.

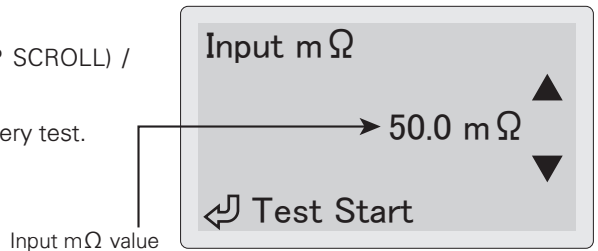

※Input internal resistance ($m\Omega$) value if it is available on the battery body or its manual. If not, test the new (full-charged) battery selecting "NO" in the above step to record the initial internal resistance. Input that value from the next testing.

※Battery condition (good / bad) cannot be tested without inputting internal resistance ($m\Omega$) value.

※Selected resistance value is retained.

BATTERY TEST

• Input Battery Temperature

(when selecting manual temperature input in page 36, "8. Temperature Setting")

Input battery temperature in °C using

△(UP SCROLL) / ▽(DOWN SCROLL) Keys.

Press ◀ (ENTER) Key to start battery test.

※Input the temperatures of the battery fluid
or ⊕ terminal.

※Selected temperature value is retained.

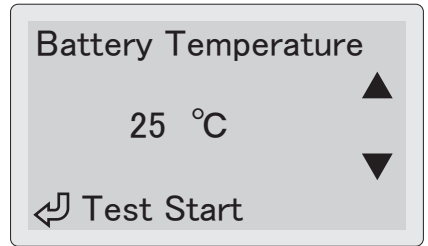

⑧ "Now testing..." is shown on LCD during battery testing.

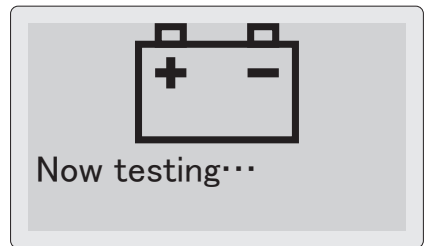

⑨ Read the test result on LCD.

Scroll the display with △(UP SCROLL) / ▽(DOWN SCROLL) Keys.

You can also check the results by LED.

- Green lights up when test result is "Good".
- Green & Yellow lights up when the battery is fine but needs re-charging.
- Yellow lights up when re-charging and retest are needed.
- Red flashes when the test result is "Caution".
- Red lights up when battery replacement is needed.

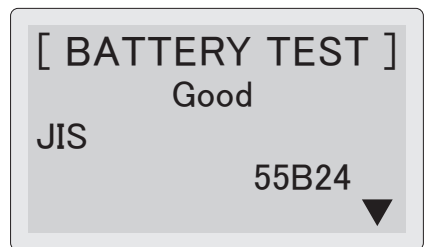
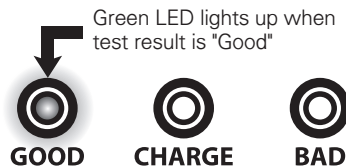

※ You can see following results on LCD.

- | | | |
|---------------------------|---|-------------------|
| • Battery test result | • CCA value (Standard mΩ for Industry) | • Battery voltage |
| • Selected battery type | • Measured CCA (measured mΩ for Industry) | • Testing method |
| • Model (in battery list) | • Temperature | • Testing Mode |
| • SOH (State of Health) | • SOC (State of Charge) | • Comment |

BATTERY TEST

- Press  (MENU) Key : Move to Menu screen in page 27
- ※For the vehicle equipped with higher grade battery, start performance of engine may have no problem even if the judgment result is "Replace". In this case, battery replacement is recommended to prevent suddenly battery breakdown.
- ※The battery which is not charged for a long term may be judged "Replace" due to decreasing CCA by self-discharge even if it is a new battery. Keep the battery with periodical auxiliary charge to prevent deterioration by leaving with exhausted condition for a long term.

- ⑩ Press  (ENTER) Key.
Select "Yes" to finish the test and return to the battery type select screen (③ in page 14).

Do you want to exit?

YES
NO



CAUTION

- Do not pull Battery Clips forcibly when detaching from the battery. It may damage the battery terminals.

- ※When intend to restart the measurement after disconnecting the battery clips, take a few seconds interval for discharging the residual electric charge from the unit.

BATTERY TEST

※Inspect following points when the instrument displays this error message.

① Check for battery clips

- Clip the battery terminals with metal serrated parts.
- Touch the metal serrated parts on the both +/- battery terminals.
- Make sure not to touch either side of the metal serrated parts on the insulated part.

② Check for the battery and vehicle

Make sure there are no dirt or abnormality on the battery terminals and terminal cables.

③ Check for SK-8536

Make sure there are not any dirt or abnormality on the metal part of battery clips and clip cables.

※Battery may be damaged if keeping getting errors in spite of checking above.

When the error message is kept displaying or measurement error is displayed even if testing another battery, ask repair service to us, KAISE CORPORATION through your local dealer.

When the unit shows this error message, immediately stop measurement and change the battery cable into the new one to avoid any accident by damaged (disconnected) cable.

Error

Restart the unit and
test again.
Check error point.

Error

Battery cable
disconnected.
Need replacing.

SYSTEM TEST

Test the Start Performance (check the engine starting ability) and Charging System (checking generating condition of alternator).

- ① Connect the instrument to the battery to be tested (see ① to ② in pages 13 to 14).
Select System Test, press **↵** (ENTER) Key.
※ Display shows the connected battery voltage.

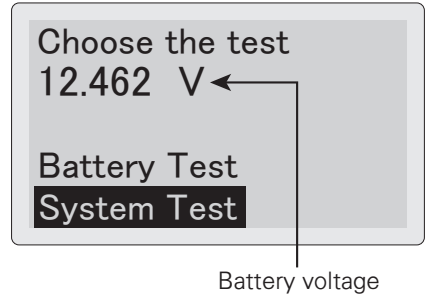

- ② Select the battery to be tested either 12V or 24V. Press **↵** (ENTER) Key.

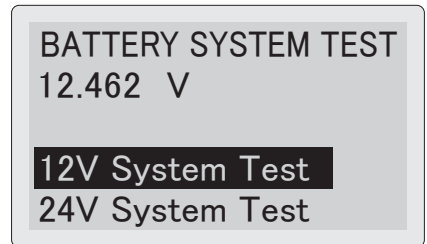

- ③ Turn off the all electric components and press **↵** (ENTER) Key.

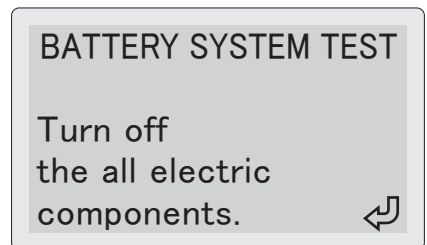

SYSTEM TEST

④ Start the engine when the instrument displays the following message.

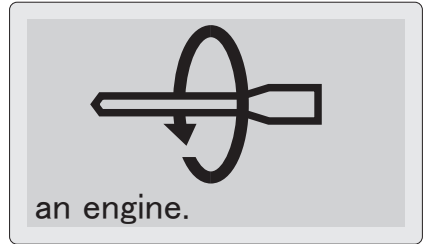
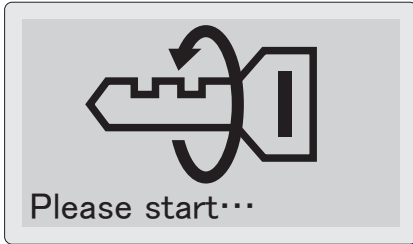

⑤ System test takes about 30 second maximum. Follow the message on the screen.

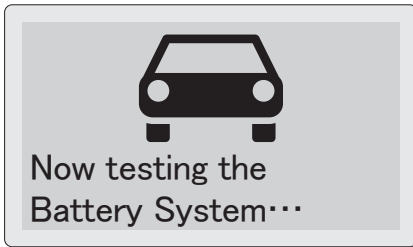

12V System

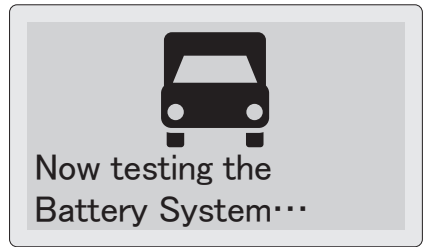

24V System

⑥ Charging System Test screen is displayed as shown in right.

Press  ENTER Key to fix the charging voltage which is varied depending on the generating condition of the alternator. Then, the instrument displays system test result as ⑦ in page 23.

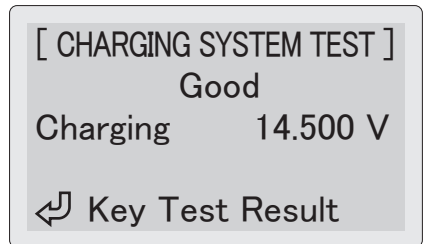

SYSTEM TEST

※The instrument displays the following message when the charging voltage is less than 13V. When measuring the vehicle with charge control system, turn on some electric components to apply electric load to the battery.

※For 24V system test, the message is shown when the charging voltage is less than 26V.

Apply electric load.
Maximum power on
the air conditioner
and headlight.



Stop the test
if charging voltage
remains in low
level.



⑦ Test Result screen as shown in the right is displayed when finishing the system test.

You can scroll the screen with Δ (UP SCROLL) / ∇ (DOWN SCROLL) Keys.

You can also check the results by LED.

- Green LED lights up when the all test results are "Good".
- Red LED flashes when engine starter system is weak.
- Red LED lights up when the whole charging system including starter system is weak.

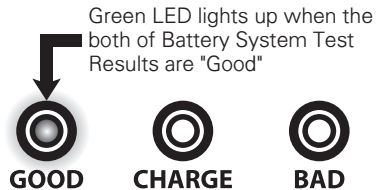

[START PERFORMANCE TEST]
Good
Cranking 8.686 V
Start Performance
100 % ▼

※You can see following results on LCD.

- Start performance test result
- Starting voltage (cranking battery voltage)
- Start performance (the ability that battery starts an engine)
- Charging system test result
- Charging voltage (battery voltage at the time of charging)
- Ripple voltage (ripple voltage of diode)
- Comment

SYSTEM TEST

- Press  (MENU) Key : Move to Menu screen in page 27.

※Though the lowest operatable / testing voltage of this instrument is 8V DC, the testing carries out normally even if the battery voltage drops lower than 8V DC during Start Performance Test.

※The unit turns off automatically when battery voltage extremely goes down under long clanking time for the reason such as weakened start performance.

※Start Performance Test is not applicable to check the starter motor condition.

※The message "Start Performance 0%" means that the tested battery almost has no power to start an engine. It does not mean the starting probability.

- ⑧ Press  (ENTER) Key.

Select "Yes" to finish the test and back to the test select screen (① in page 21).

Do you want to exit?

YES
NO



CAUTION

- Do not pull Battery Clips forcibly when detaching from the battery. It may damage the battery terminals.

※When intend to restart the measurement after disconnecting the battery clips, take a few seconds interval for discharging the residual electric charge from the unit.

PC CONNECTION

SK-8536 can connect to PC via provided USB cable. You can send saved test data to PC in text format.

- ① Insert the provided USB cable to the USB port on the right side of the unit and connect another side to PC.

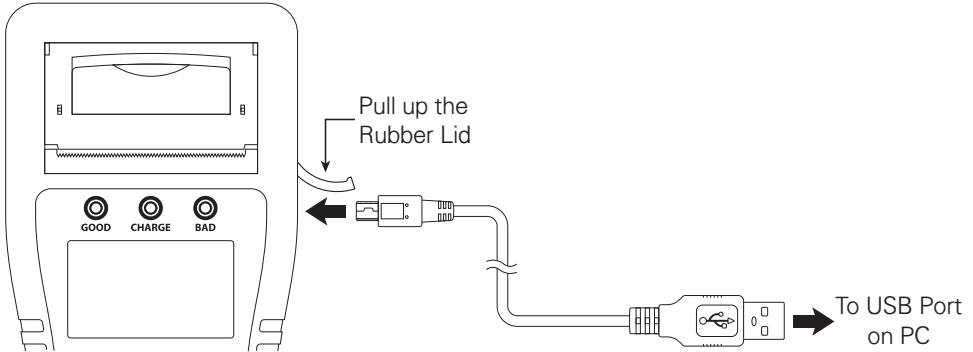

- ② The instrument turns on automatically when connecting to active PC. Messages as shown in the right are displayed.

- ※ Internal memory is recognized as mass-storage device (kaise SK-8536 USB Device) when PC connection is completed.
- ※ If your PC does not recognize the SK-8536, try to use another USB port or to connect through commercially available USB hub.
- ※ It may take time to recognize the devise.

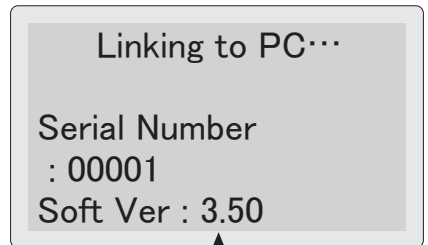

Current version number is displayed.

- ③ Access to the memory of this instrument by PC operation to copy and paste the data to the PC. Data format is "text" which is suitable for print out from PC.

PC CONNECTION

<Examples of saved data>

Battery Test

2231501B.TXT - Notepad

Battery Test Report

Date and Time: 2022/03/15 15:00

(Aging Test Mode)

Test Result: Good

Battery Type: JIS
Battery Size: Q-85
Rated CCA: 590CCA
Measured CCA: 615CCA
Battery Voltage: 12.780V
Battery Temperature: 24°C
Testing Mode
: Charge Controller/Idle Reduction

SOC (State of Charge): 100%

SOH (State of Health): 100%

Comment

Periodical test is recommended.

Annotations:
- Test date and time: 2022/03/15 15:00
- Test mode: (Aging Test Mode)
- Test result: Good
- Details of tested battery: Battery Type, Size, CCA, Voltage, Temperature, Testing Mode
- Battery charging level (SOC): SOC (State of Charge): 100%
- Battery aging level (SOH): SOH (State of Health): 100%
- Comments for test result: Comment, Periodical test is recommended.

System Test

2231501S.TXT - Notepad

System Test Report

Date and Time: 2022/03/15 15:00

(12V System)

Start Performance Test

Test Result: Good

Cranking: 8.619V
Start Performance: 100%

Charging System Test

Test Result: Good

Charging Voltage: 14.523V
Ripple Voltage: 0.110V

Comment

Periodical test is recommended.

Annotations:
- Test date and time: 2022/03/15 15:00
- 12V/24V system: (12V System)
- Test result: Good
- Result details: Cranking: 8.619V, Start Performance: 100%
- Test result: Good
- Result details: Charging Voltage: 14.523V, Ripple Voltage: 0.110V
- Comments for test result: Comment, Periodical test is recommended.

※Test data are displayed in the language used for data saving.

④Detach USB Cable after completing "Safety Remove Hardware" process from PC.



CAUTION

- Detach USB Cable after completing USB removing process from PC to prevent unexpected trouble.

※When intend to restart the measurement after disconnecting the battery clips, take a few seconds interval for discharging the residual electric charge from the unit.



※Windows is a registered trademark of the Microsoft.

MENU

1. Print Out

Print out the Battery Test and System Test results from built-in printer.

※Unclear printing or unstable operation of this instrument may occur when using weak battery for printing. In this case, save the test results in reference to "2. Save the Test Result" in page 30, then print them out with good battery or PC in reference to " PC Connection" in page 25.

① Press  **(MENU) Key** in Battery Test result (⑨ in page 18) or System Test result (⑦ in page 23) screens to enter Menu screen. Select " Print" and press  **(ENTER) Key**.

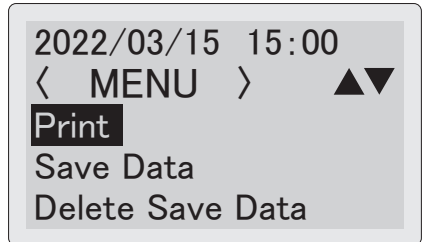

② Select " YES" and press  **(ENTER) Key**.
The instrument starts printing.

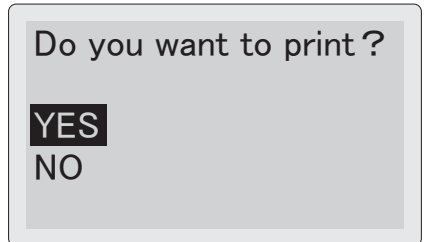

※If printing becomes dark by continuous printing, stop printing for a while for cooling down the printer thermal head.

※When the thermal head is too much heated, warning shown on LCD and printing stops. Leave the unit for a while for cooling down.

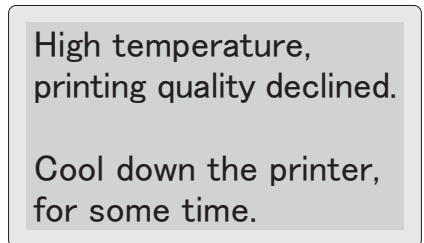

※The instrument displays right screen during printing. After finishing, go back to test result screen.

※Make sure to close printer cover to avoid any printing error.

※When paper jam occurs, open the printer cover and fix the paper.



MENU

- ※The instrument displays right screen when printer paper is almost empty or unset. Set new printer paper as per "1. Changing the Printer Paper in page 37.
- ※This screen may not be displayed depending on the sensor sensitivity.
- ※Use genuine printer paper (model : 851). Using other paper could cause printing error or device failure.

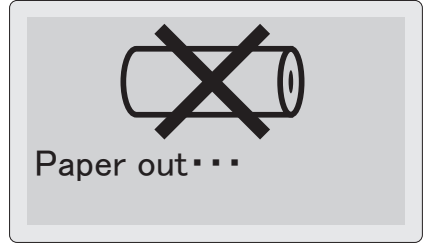

Printing Sample

- ※Saved data is printed out with a current setting language of this instrument.
(e.g. : The data saved in Japanese is printed in English if the present setting is "English".)

Battery Test

Battery Test Report

Store Name _____

Person in Charge _____

Date and Time
2022/03/15 15:00 •

(Aging Test Mode) •

Test Result : Good •

Battery Type _____ JIS
Model No. _____ Q-85
Measured CCA _____ 615CCA
Battery Voltage _____ 12.780V
Temperature _____ 24°C
Testing Mode _____
Charge controller / Idle Reduction _____

SOC (State of Charge) : 100% •



SOH (State of Health) : 100% •



Periodical test is recommended.

Store name and person in charge

Testing date and time

Battery test mode

Battery test result

Condition of tested battery

Battery charging level (SOC)

Battery aging level (SOH)

Comment for test result

■ System Test

System Test Report

Store Name _____

Person in Charge _____

Date and Time
2022/03/15 15:00 •

(12V System) •

START PERFORMANCE TEST

Test Result : Good •

Cranking _____ 8.619V

Start Performance _____ 100%

CHARGING SYSTEM TEST

Test Result : Good •

Charging Voltage _____ 14.523V

Ripple Voltage _____ 0.110V

Periodical test is recommended.

Store name and person in charge

Testing date and time

12V / 24V System

Engine start performance test result

Battery conditions at engine starting

Charging system test result

Battery conditions

Comment for test result

MENU

2. Save the Test Result



Save the results of Battery Test and System Test up to 359 data.

※Each data is saved with following file name.

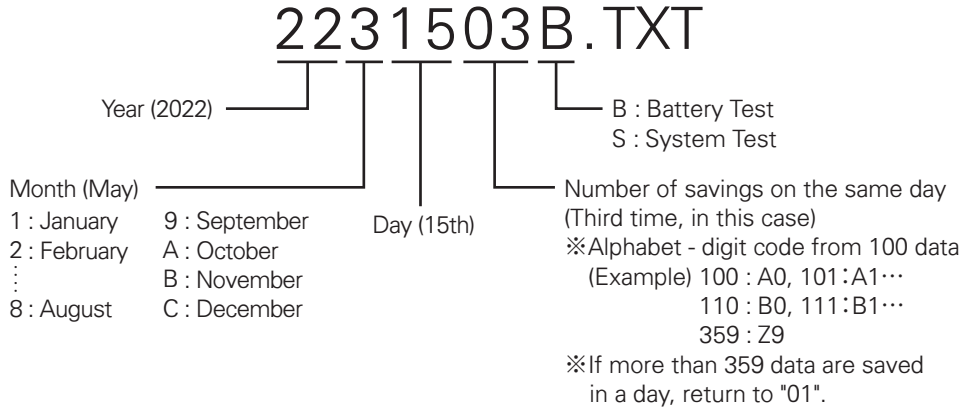
■Example of file name (In case of the third time on the same day, March 15th, 2022)



※Saved date and time reflect the date and time settings of this instrument. Make sure to set them correctly in reference to "5. Date and Time Setting" in page 34.

- ① Press  (MENU) Key in Battery Test result (⑨ in page 18) or System Test result (⑦ in page 23) screens enter Menu screen. Select "Save Data" and press  (ENTER) Key.

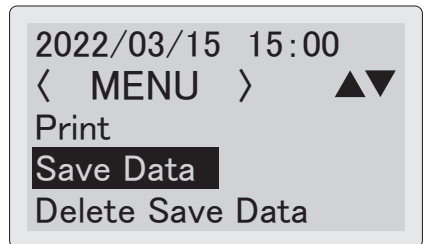

- ② Select " YES" and press  (ENTER) Key to save the test data.

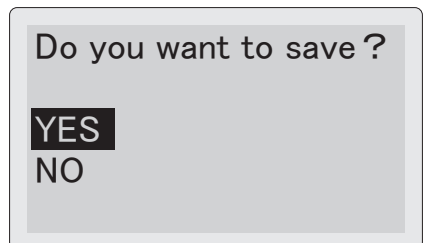

MENU

※Up to 359 data can be saved to the internal memory. The instrument displays this WARNING if the saved data exceeds 359. Delete unnecessary data in reference to "4. Delete the Saved Data" in page 33.

-WARNING-
**Can't save the data.
The number of saved
data exceed the limit.**

※The instrument displays this WARNING when the memory capacity shortage. Delete unnecessary data in reference to "4. Delete the Saved Data" in page 33 to make the storage capacity.

-WARNING-
**Can't save the data.
Out of memory
capacity.**

※The instrument displays this WARNING when the same data already exists. Delete the relevant in reference to "4. Delete the Saved Data" in page 33.

-WARNING-
**Can't save the data.
The same file name
existed.**

※File name consists of the saving date. Refer to "Example of file name" in page 30 for details.

※Saved data are deletable from PC (refer to "PC Connection" in page 25).

※The instrument displays this message when the system error occurs.

Stop test and format the removable disk in reference to "3. Formatting the Removable Disk" in page 40.



※All of the saved data are deleted after formatting removable disk.

System Error
Can't save the data.

MENU

3. View the Saved Data

Recall the saved data to see on the screen.

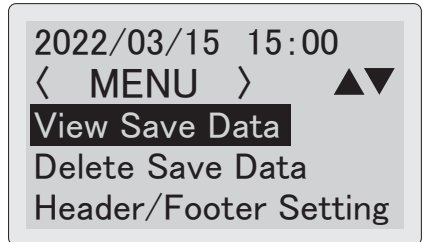

① Press  (MENU) Key in "Choose the Test" screen (③ in page 14) to enter Menu screen. Select "View Save Data" and press  (ENTER) Key.

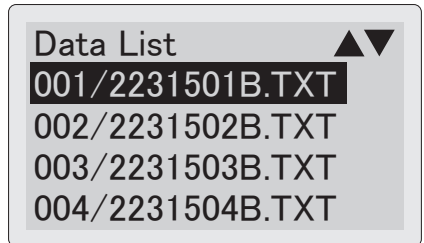

② Select the data that you want to see, and press  (ENTER) Key.

※ If there is no saved data, "No data found" is displayed.



③ Saved data are displayed as shown in the right. Scroll the data by  (UP SCROLL) /  (DOWN SCROLL) Keys.

※ Press  (MENU) Key to print the viewing data. See "1. Print Out" in page 27 for details.

※ Saved data is displayed in a current setting language of this instrument.
(e.g.: If English is set now, every data saved in Japanese are displayed in English.)

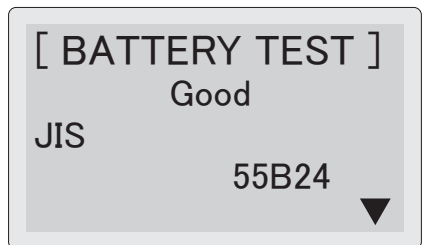

※ The instrument displays this message when the system error occurs.
Stop test and format the removable disk in reference to "3. Formatting the Removable Disk" in page 40.

※ All of the saved data are deleted after formatting removable disk.

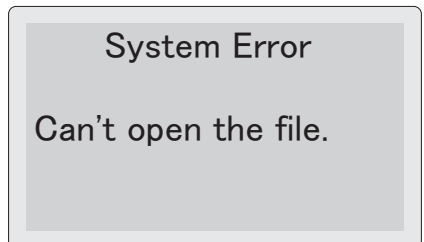

MENU

4. Delete the Saved Data

Saved data can be deleted in the following procedures.

① Press  (MENU) Key in "Choose the Test" screen (③ in page 14) or test result screens (⑨ in page 18 / ⑦ in page 23) to enter Menu screen.

Select "Delete Save Data" and press  (ENTER) Key.

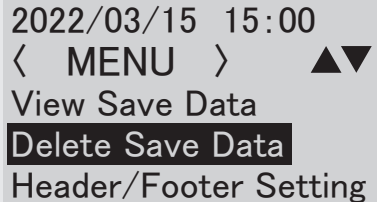

2022/03/15 15:00
< MENU > ▲▼
View Save Data
Delete Save Data
Header/Footer Setting

② Select the data to delete from the data list, and press  (ENTER) Key.

※ If there is no saved data, "No data found" is displayed.

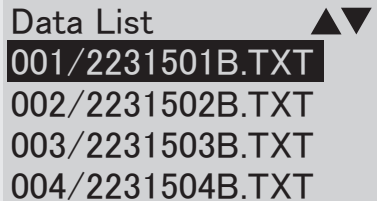

Data List ▲▼
001/2231501B.TXT
002/2231502B.TXT
003/2231503B.TXT
004/2231504B.TXT

③ Select " YES" and press  (ENTER) Key to delete the test data.

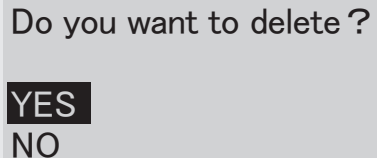

Do you want to delete ?
YES
NO

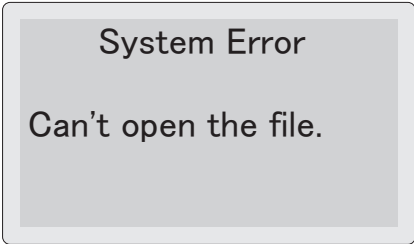

※ When system error occurs, the message as shown in the right is displayed. Stop testing and format Removable Disk in reference to "3. Formatting the Removable Disk" in page 40.

※ All saved data are deleted after formatting removable disk.



System Error
Can't open the file.

5. Date and Time Setting



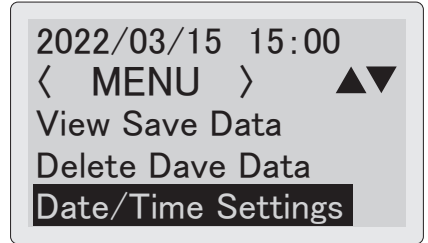

① Press  (MENU) Key in "Choose the Test" screen (③ in page 14) or test result screens (⑨ in page 18 / ⑦ in page 23) to enter Menu screen.
Select "Date/Time Settings" and press  (ENTER) Key.

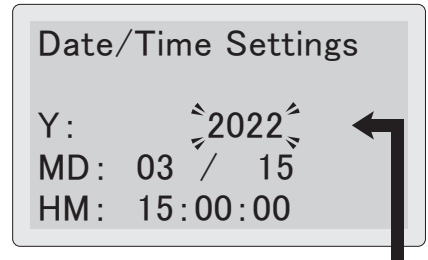

② Date/Time Setting screen is displayed.
(Year (Y) is blinking)



Year blinks.

③ Set "Year" with using  (UP SCROLL) /  (DOWN SCROLL) Keys and press  (ENTER) Key. Then "Month" starts to blink. Set "Month" and press  (ENTER) Key, Set the "Day" in the same way.

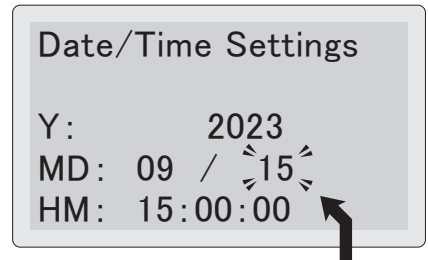

The next setting blinks by pressing  (ENTER) Key.

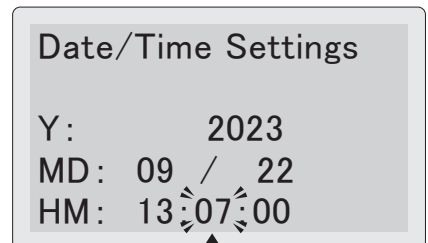

④ Set Time (HM) until minute. Press  (ENTER) Key. Date/Time Settings are fixed with resetting "Second" to 00 and return to Menu Screen (previous Step ①).





Set until minute,
then press  (ENTER) Key.

MENU

6. Language Setting

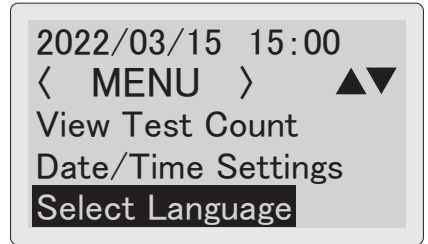

- ① Press  (MENU) Key in "Choose the Test" screen (③ in page 14).
Select "Select Language" and press  (ENTER) Key.



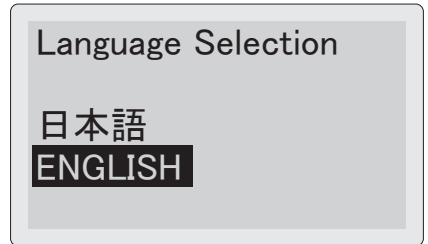



- ② Select preferred language and press  (ENTER) Key.
Language is fixed and return to Menu screen.

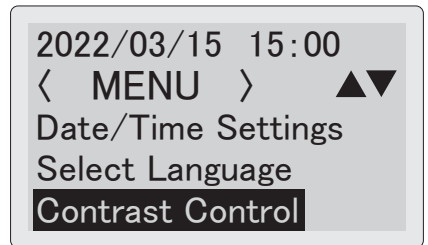

7. Contrast Adjustment

- ① Press  (MENU) Key in "Choose the Test" screen (③ in page 14) or test result screens (⑨ in page 18 / ⑦ in page 23) to enter Menu screen.
Select "Contrast Control" and press  (ENTER) Key.



- ② Adjust LCD contrast in the range of 0 - 30 with  (UP SCROLL) /  (DOWN SCROLL) Keys.
Press  (ENTER) Key to fix the contrast and return to Menu screen.

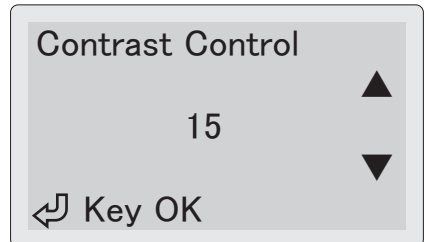



MENU

8. Temperature Setting

Set the battery temperature input mode in Battery Test.

Default setting is "Auto". You can change it to "Manual" if necessary.

- ① Press  (MENU) Key in "Choose the Test" screen (③ in page 14) to enter Menu screen. Select "Temperature Setting" and press  (ENTER) Key.

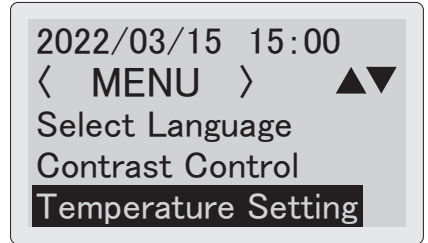

- ② Select "Manual" if you prefer to input the battery temperature manually in Battery Test (see page 18).

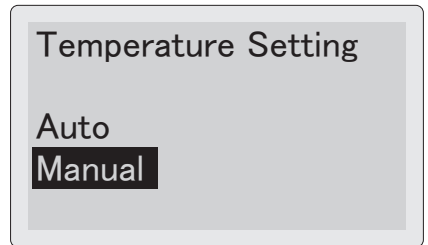

Press  (ENTER) Key to return to Menu screen.

※Default setting is "Auto".



9. Rated CCA Value Print

- ① You can select Print or Not Print the Rated CCA.

Press  (MENU) Key in "Choose the Test" screen (③ in page 14) to enter Menu screen. Select "Rated CCA Value Print" and press  (ENTER) Key.

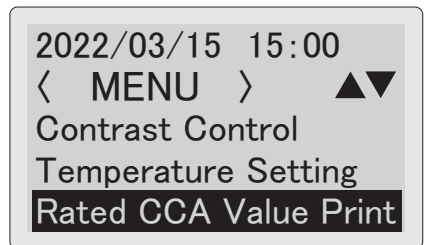

- ② Select "No" if you do not print Rated CCA. Press  (ENTER) Key, the screen returns to Menu screen.

※If "No" is selected, PC-saved data does not show Rated CCA also. Refer to page 26.

※This function is effective only for the battery chosen from installed battery list or its favorite.

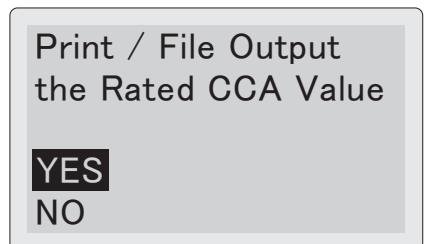

MAINTENANCE

1. Changing the Printer Paper

The instrument displays this screen when the printer paper is running out or unset. Set the new one in the following procedure.

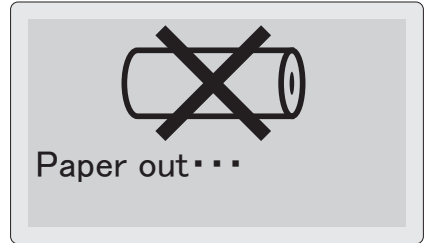

- ① Pull up printer lever as shown in the right. printer cover lifts up.

※ **Do not pull up / open the printer lever or printer cover forcibly to avoid any damage to the instrument.**

- ② Open the printer cover and remove old printer paper.

- ③ Prepare the new paper.
Peel off the fixing seal, and put it into the printer compartment.
Be sure to put the inner side (printable side) to downward as shown in the right.

- ④ Pull the paper forward so that it extends past the serrated edge of the paper slot.

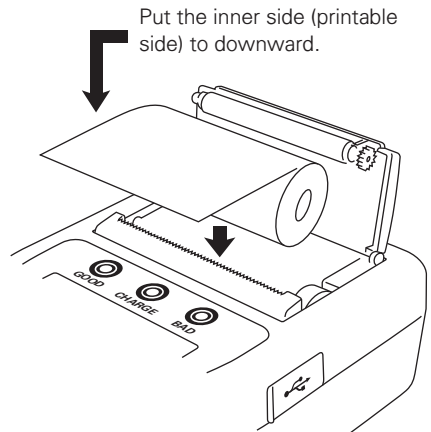
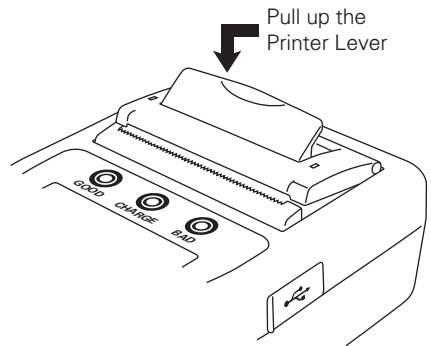

CAUTION

- Do not pull up / open the printer lever or printer cover forcibly to avoid any damage to the instrument.
- Be sure to put the printer paper facing the inner side (printable side) to downward. Cannot print on the reverse side.

MAINTENANCE

⑤ Close the printer lever, then close the printer cover with putting it over the pulled out paper. Cut off the extra paper.

※ Be sure to push the both ends of printer cover when closing. Pushing center part may damage the cover or the printer module.

Close the printer cover pushing both ends. (Do not push center part.)

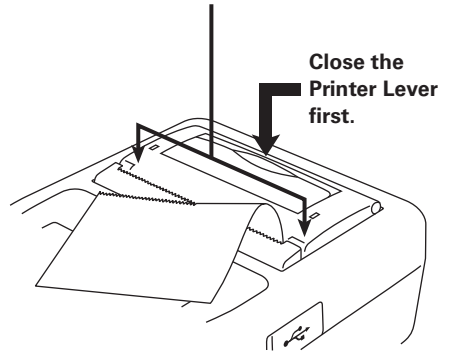

CAUTION

- To avoid any trouble or damage to the printer module, be sure to close the printer lever first when closing printer cover.
- Be sure to push the both ends of printer cover when closing. Pushing center part may damage the cover or the printer module.
- To prevent discoloration, do not place the printer paper under in any place where it will be subjected to direct sunlight or high temperatures / humidity.
- Keep this instrument in the supplied carrying case to avoid malfunction of the printer trouble by dust penetration.
- Be careful not to put the dust in the printer compartment to prevent any malfunction of the printer.
- Be sure not to reach the dust into the gear wheel part to prevent printer trouble.
- Do not keep this instrument in the dusty area to prevent printer trouble.
- Use genuine printer paper (model : 851). Using other paper could cause printing error or device failure.

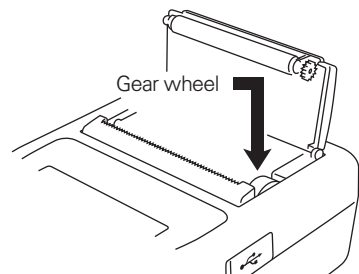

MAINTENANCE

2. Printhead Cleaning

Clean the printhead as per the below procedures, in case of faded printing error cause by dirty printhead.

① Open printer cover and remove printer paper.

※ See page 37 how to open printer cover.

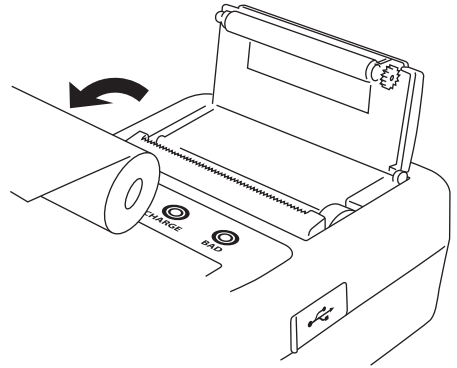

② Steep cotton swab in ethyl alcohol, and wipe the printhead.

If it is not enough, rub the printhead with cloth, applying ethyl alcohol on it.

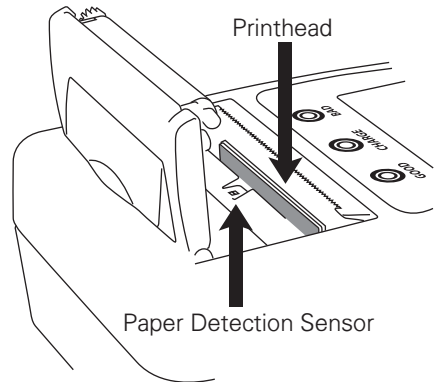

Cleaning Paper Detection Sensor:
Use dry cotton swab to wipe off without using ethyl alcohol.



CAUTION

- Do not wipe / rub the printhead strongly. This may hurt printhead or cause printing error.
- Do not use methyl alcohol, toxic to humans.
- Do not use any sharp or hard materials for printhead cleaning.



MAINTENANCE

3. Formatting the Removable Disk



CAUTION

● All of the saved data are deleted after formatting removable disk.

- ① Connect the instrument to car battery (see page 13) or PC (see page 25) holding down  (ENTER),  (UP SCROLL), and  (BACK) Keys. The instrument turns on.

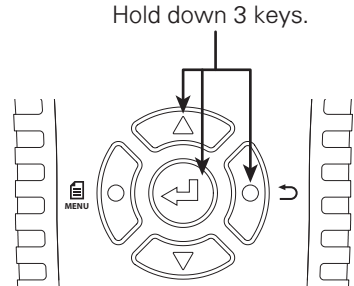

- ② The instrument displays this message. Press  (ENTER) Key to start formatting the removable disk.
- ※ Turn off the instrument to quit the formatting.
 - ※ The instrument also displays this screen when removable disk has an error. In this case, format the disk in the same way.
 - ※ Do not turn off the instruments during the disk formatting is proceeding.

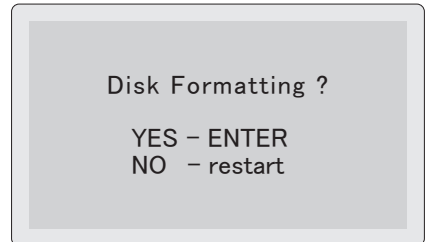

- ③ Instrument restarts automatically after completing the disk formatting.

MAINTENANCE

4. DMP Folder

When measurement error occurs during the battery test process, the instrument creates DMP folder in the removable disk to save the internal error data.

You do not need to delete this.

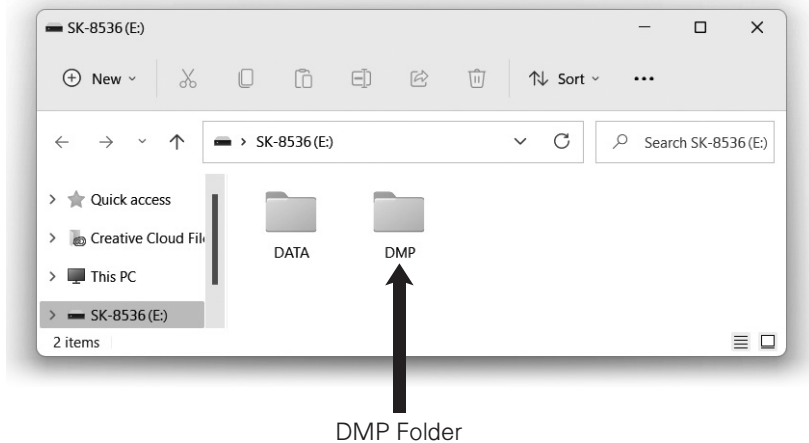

5. Periodical Check and Calibration

Periodical check and calibration is necessary to make safety measurements and to maintain the specified accuracy. The recommended check and calibration term is once a year and after the repair service. This service is available at KAISE AUTHORIZED SERVICE AGENCY through your local dealer.

6. Software Version Update

- You can update the internal software from our website (<https://www.kaise.com/NewEnglish.htm>) when it is available. Download the file in reference to the loading procedures.

7. Others

- If the metal part of the battery clip is soiled, wipe it off with soft cloth to obtain the accurate measurement.
- If Date and Time are not able to set, internal backup battery is exhausted. Ask KAISE AUTHORIZED SERVICE AGENCY through your local dealer for repair service.

TROUBLE SHOOTING & REPAIR

If there are any failure with this instrument, check the following trouble shoots before asking repair service. Ask KAISE CORPORATION AUTHORIZED SERVICE AGENCY through your local dealer when there are any questions or troubles with this instrument.

Symptoms

Possible Causes and Necessary Treatments

Cannot turn on the instrument

- Battery Clips are connected in the wrong polarity.
→ Connect Black clip to minus \ominus , and red clip to plus \oplus battery terminals.
- Battery voltage goes down to 8V or lower.
→ Recharge the battery.
- Weak connecting of battery cable or USB cable.
→ Insert their plugs deeply.
- Metal parts of battery clips or battery terminals have problems.
→ Make them clean and check if there are not damaged.
- Battery cable is damaged (disconnected).
→ Replace with the new battery cable.

Cannot save, view and delete data

- System error is occurring.
→ Format the Removable Disk in reference to "3. Formatting the Removable Disk" in page 40.

Instrument freezes with English letters on LCD

- There is an error in removable disk.
→ Format the disk in reference to "3. Formatting the Removable Disk" in page 40.

Date / Time are not saved

- Backup battery (built-in) is exhausted.
→ Ask KAISE AUTHORIZED SERVICE AGENCY through your local dealer for repair service.

LCD displays Measurement Error

- Metal part of the battery clip or battery terminal is soiled.
→ Remove it cleanly.
- There is an abnormality in the battery.
→ Check visually the appearance of the battery; dirt of the terminal, abnormality of the terminal cable, etc.
- Battery cable is damaged (disconnected).
→ Replace with the new battery cable.

TROUBLE SHOOTING & REPAIR

Symptoms

Possible Causes and Necessary Treatments

**Screen shows
"Disk Error ..."**

- The instrument has system error.
→ Format the disk in reference to "3. Formatting the Removable Disk" in page 40.

**Wrong
test results**

- Weak connection between battery clips and battery terminals.
→ Check battery clips to touch their metal serrated parts on both black and red battery terminals.

Faded printing

- Printhead becomes dirty.
→ Clean the printhead as per procedures in page 39.
→ Use genuine printer paper (model : 851).

**Printer does
not work**

- Printer paper is set in reverse.
→ Place the paper correctly in reference to "1. Changing the Printer Paper" in page 37.
- Printer is jammed.
→ Open printer cover and pull out the printer paper.
- Wrong printer paper is using.
→ Use genuine printer paper (model : 851).
- Paper detection sensor is dirty. (Screen shows "Paper out..." even if printer paper remains enough.)
→ Wipe off paper detection sensor by cotton swab (refer to page 39).

**Not recognized
by PC**

- Removable disk in this instrument is damaged.
→ Format the removable disk.
(Refer to "3. Formatting the Removable Disk" in page 40)
- Poor compatibility with your PC.
→ Use USB hub to connect with PC.

ABOUT KAISE WEBSITE

1. SK-8536 Product Page

Product information, Data sheet (PDF), Instruction manual (PDF) are available.

SK-8536 Product Page URL

https://www.kaise.com/e_car_sk8536.html



You can also access through:

Kaise Website (<https://www.kaise.com/NewEnglish.htm>) → Products → Automotive Testers
→ SK-8536 Battery Checker

WARRANTY

SK-8536 is warranted in its entirety against any defects of material or workmanship under normal use and service within a period of one year from the date of purchase of the original purchaser. Warranty service is available at **KAISE AUTHORIZED SERVICE AGENCY** through your local dealer. Their obligation under this warranty is limited to repairing or replacing SK-8536 returned intact or in warrantable defect with proof of purchase and transport charges prepaid. **KAISE AUTHORIZED DEALER** and the manufacturer, **KAISE CORPORATION**, shall not be liable for any consequential damages, loss or otherwise. The foregoing warranty is exclusive and in lieu of all other warranties including any warranty of merchantability, whether expressed or implied.

This warranty shall not apply to any instrument or other article of equipment which shall have been repaired or altered outside of **KAISE AUTHORIZED SERVICE AGENCY**, nor which have been subject to misuse, negligence, accident, incorrect repair by users, or any installation or use not in accordance with instructions provided by the manufacturer.

KAISE AUTHORIZED DEALER

kaise

KAISE CORPORATION

422 Hayashinogo, Ueda City, Nagano Pref., 386-0156 Japan

TEL : +81-268-35-1601 / FAX : +81-268-35-1603

E-mail : sales@kaise.com

<https://www.kaise.com>

Product specifications and appearance are subject to change without notice due to continual improvements.